

Safety Grating

GSHDGS-13R

Heavy duty GRIP STRUT™ safety grating

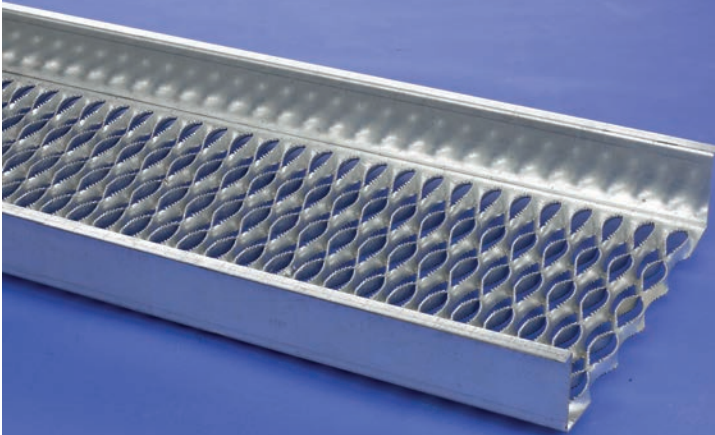

B-Line
by **FATON**

Table of Contents

| | |
|--|---------|
| Advantages | 3 |
| General Load Information | 4 - 6 |
| Multi-Plank Width Comparison Chart | 7 |
| Design Load Tables | |
| 2-Diamond Planks - 9 ¹ / ₄ " Width (Steel & Aluminum) | 8 - 9 |
| 3-Diamond Planks - 13 ³ / ₄ " Width (Steel & Aluminum) | 10 - 11 |
| 5-Diamond Planks - 23 ¹ / ₄ " Width (Steel) | 12 - 13 |
| 6-Diamond Planks - 27 ³ / ₄ " Width (Steel) | 14 - 15 |
| 8-Diamond Planks - 36" Width (Steel) | 16 - 17 |
| Walkways | |
| 5-Diamond - 24" Width (Steel) | 18 - 19 |
| 6-Diamond - 30" Width (Steel & Aluminum) | 18 - 19 |
| 8-Diamond - 36" Width (Steel) | 18 - 19 |
| Stair Treads | 20 - 21 |
| Special/Fabricated Products | 22 |
| Accessories | |
| Hold-Down Clip | 22 |
| Walkway Splice Plates | 22 |
| Handrail Brackets | 23 |
| Specifications | 24 - 25 |
| How To Order | 26 |

H-Series

Heavy Duty Grip Strut™

Gratings for Greater Loads, Safer Walking

- High strength-to-weight ratio — efficient structural design means large-load capacity with low dead weight
- Slip resisting surface — scores of tiny teeth grip shoes tightly (exceeds Federal Specification RR-G-1602D slip-resistance requirements)
- Open design — sheds slip-causing stones, dirt and debris
- Slip-resisting serrated or less harsh non-serrated wearing surfaces tailor long life to diverse service conditions — sheds slip-causing stones, dirt and debris
- Complete line of products, design data, support services
- Handrail brackets available for maximum safety and meeting OSHA requirements
- Splice plates speed assembly without welding
- Integral, OSHA compliant toeboards. Canadian compliant OH&S designs available in some sizes.

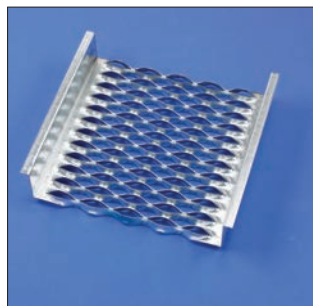

Heavy Duty GRIP STRUT Walkway
Helps provide safer walking surface

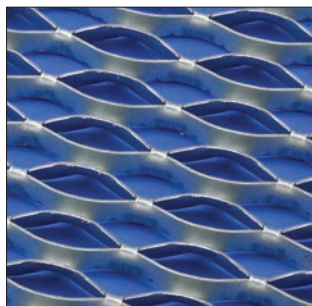

Heavy Duty GRIP STRUT Pattern - No Teeth -
Labor saving alternative to bar grating
Lowest installed solution

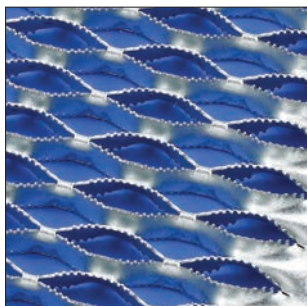

Heavy Duty GRIP STRUT Pattern - Standard With Teeth -
Safety, self cleaning and self draining all-in-one



Heavy Duty GRIP STRUT Walkway - Reduced Opening -
Limits items from falling through openings for safety below

Every year, falls cost industry millions of dollars in lost time and production. The safer walking-working surfaces of Heavy Duty GRIP STRUT™ safety grating products help reduce accidents, and in doing so, may help cut insurance costs.

The secret is in the serrated surface and open design. The open diamond pattern allows fluids, mud, chips, ice and snow to fall through. The serrated surface helps provide high friction for maximum slip protection in all directions, and under practically all conditions. The resilience of GRIP STRUT grating cushions the impact of walking, lessening worker fatigue and increasing efficiency.

Heavy Duty GRIP STRUT safety grating products offer the advantage of regular GRIP STRUT safety grating, but are designed for applications of greater load and/or longer span. Basic design is the same, but diamond openings are larger and metal is thicker. Heavy Duty grating products are available in many of the same configurations, materials and finishes as regular GRIP STRUT safety grating. Heavy Duty GRIP STRUT grating products include: planks, walkways and stair treads; for specification see pages 24 & 25. For specifications and information on regular GRIP STRUT safety gratings, see GRIP STRUT safety gratings & stair treads catalog, available from your local distributor or contact us directly.

High load capacity, long life

High strength-to-weight performance is achieved through section depth and integral side-channel design. Bridged struts form a rigid, strong plank surface that carries large loads with minimum deflection. There are no rivets, fabricated joints or pressure joints to loosen or break.

Safety at all levels

Heavy Duty GRIP STRUT safety grating's serrated surfaces grip soles securely in all directions. These non-slip sheared edges are ideal for both indoor and outdoor locations — wherever mud, ice, snow, oil and detergents can create hazardous walking conditions.

Minimal maintenance

Openings allow fluids, chips, stones and mud to quickly drop through. Ice easily shears off under normal foot pressure. Open design is easily cleaned with a brush, liquid or air spray.

Application versatility

A variety of standard plank widths and channel heights can be combined with numerous special-order items to meet almost

any application requirement. Special sizes and fabricating services are available for unusual requirements. Heavy Duty GRIP STRUT grating products may be painted, hot-dip galvanized after fabrication, anodized, plated, plastic-coated or specially finished in other ways to fit service requirements. Finish coatings are economically applied since all surfaces are accessible to brush or spray.

Compliance with regulatory codes / standards

Wherever maximum safety underfoot is critical, GRIP STRUT safety grating is ideal, offering slip resistance exceeding Federal Specification RR-G-1602D requirements. Heavy Duty GRIP STRUT walkways meet OSHA toeboard requirements for elevated structures with standard upturned, 5 inch high integral side channels.

Low life-cycle cost

Lower upfront material costs and long-lasting, corrosion-resisting finishes help provide long service life to all GRIP STRUT gratings: steel or aluminum. Brawny but lightweight, these planks, walkways and stair treads permit substantial reduction in supporting structural materials. Self-cleaning open design is virtually maintenance-free.

Fast, simple Installation

GRIP STRUT safety grating is light and simply installed. Often, regular maintenance personnel can do the job. Sections are easily field-cut, at virtually any angle, and field-adapted; connections are rapidly made with bolts, clamps or welding. Disassembly, when needed, can be just as rapid.

Tested performance

Statistics show falls as the second highest cause of lost-time injuries in industry. Yet tests prove that falls can be reduced by the safe surface of Heavy Duty GRIP STRUT safety grating, planks, walkways and stair treads. And fewer accidents mean lower workmen's compensation insurance costs, to save the cost of GRIP STRUT safety grating many times over. Independent laboratory tests prove that Heavy Duty GRIP STRUT safety grating exceeds Federal Specification RR-G-1602D requirements for slip resistance. Five shoe soles were tested, in longitudinal, transverse and diagonal directions; under five conditions: dry, greasy, muddy, soapy and icy. Heavy Duty GRIP STRUT safety grating tested more slip-resistant than other gratings (depending upon the condition).

Tested Performance – Slip Resistance vs. Federal Specification

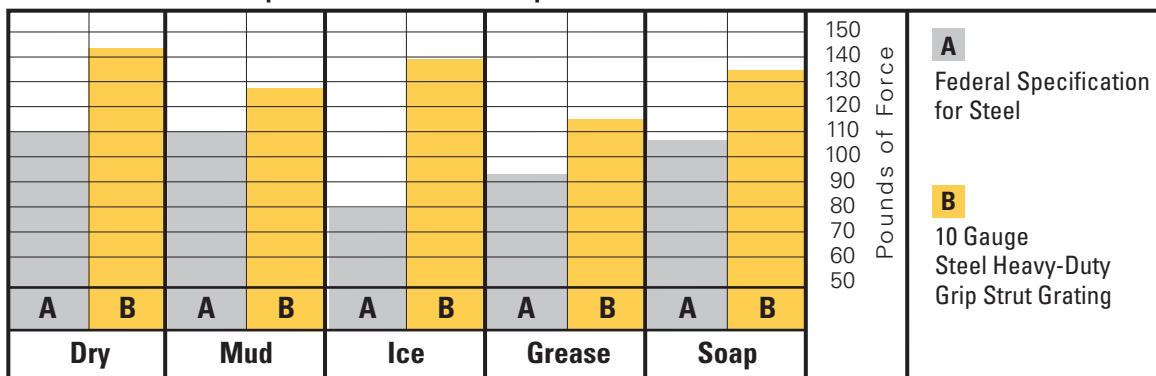

(1) Value of force required to move 1 175 lb. load a distance of one inch across the grating surface of two Heavy-Duty GRIP STRUT serrated style safety gratings (B & C) compared with the respective Federal Specification RR-G-1602D standard (A). Letter coding is as follows:

*A — standard established for steel grating with each type of condition, by Federal Specification RR-G-1602D.

*B — average of tests on Heavy Duty GRIP STRUT safety gratings of 10 gauge steel.

Values were determined by test made in longitudinal, transverse and diagonal directions on each grating with five sole materials: leather, boot rubber, shoe rubber, Neolite† and Hypaton®†.

† Mark shown is the property of its respective owner.

General Load Information

Heavy Duty GRIP STRUT™ Walkways, Planks and Stair Treads

General Load Information

Heavy Duty GRIP STRUT safety grating walkways and planks are available in three thicknesses of steel and one of aluminum; walkways have one standard siderail height, planks have four. In each category, walkways come in three widths, planks in five. Begin sizing, for maximum economy, with widest practical grating for the job (shallowest siderails and thinnest gauge); if this does not meet required load capacity, first consider deeper siderails, then heavier gauge, and finally narrower grating width, if necessary.

Flexural load tables have been calculated according to design load limiting criteria, and if not illustrated in this catalog they can be obtained from our technical services.

“Strut Load Tables” show flexural strength and deflection of individual grating surface struts relative to siderails. Since these are maximum values in the elastic range, lesser loads and deflections can be proportioned from them.

Design load assumptions differ according to load type: (1) uniform, (2) concentrated (see Figures 1, 2 and 3 below for explanation of load application). Concentrated load capacities generally vary with span, siderail height and material thickness, irrespective of grating width, although large differences in grating width cause concentrated loads to be distributed somewhat differently into siderails.

Siderail strength usually controls, but with shorter spans, deeper siderails, and/or wider grating surfaces, flexural strength of individual struts may control. In sizing walkways or planks with strength as a design criterion, be sure to check Heavy Duty GRIP STRUT safety grating for both: (1) strength of walkways/plank siderails, (2) strength of individual struts in grating surface. With deflection as a design criterion, loads may be limited by either: strength of individual surface struts, or total deflection of one siderail at midspan plus a surface strut at midwidth of walkway or plank (sum of siderail deflection plus strut deflection).

All load tables show maximum loads, based upon actual load tests performed at the Pinckneyville (IL) plant, and determined in accordance with AISI “Specification for the Design of Cold-Formed Steel Structural Members”, 1980 Edition, using minimum yield strength of 33 ksi for steel, 23 ksi for aluminum. Loads are designated:

-
- (U) for uniform, in./ft.²
 - (C) for concentrated, in./lb.
 - (D) for corresponding deflections, in inches
-

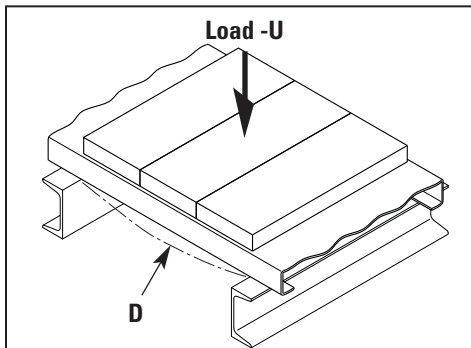

Figure 1
Uniform Load (U)
applications to all walkways/planks:
Maximum load (lb./ft.²) permitted by flexural stress in siderail or grating strut, whichever is lower, applied to entire grating area (full-width by clear-span) between supports.
Deflection (D) in all walkways/planks:
Deflection (in.) corresponding to maximum load (U) or (C) permitted by flexural stress in siderail or grating strut, whichever is lower, applied as defined in Figures 1 or 2, and 3.

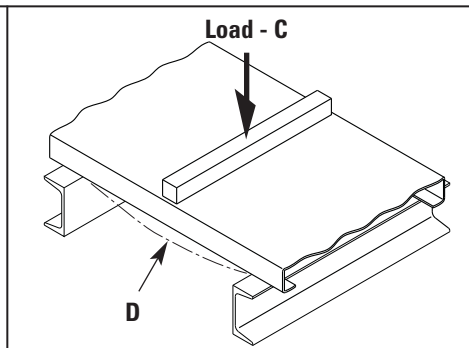

Figure 2
Concentrated Load (C)
applications to all walkways/planks:
Maximum load (lb.) permitted by flexural stress in siderail or grating strut, whichever is lower, applied transversely to total width of grating at midspan and assumed to be carried equally by both siderails.
Deflection (D) in all walkways/planks:
Deflection (in.) corresponding to maximum load (U) or (C) permitted by flexural stress in siderail or grating strut, whichever is lower, applied as defined in Figures 1 or 2, and 3.

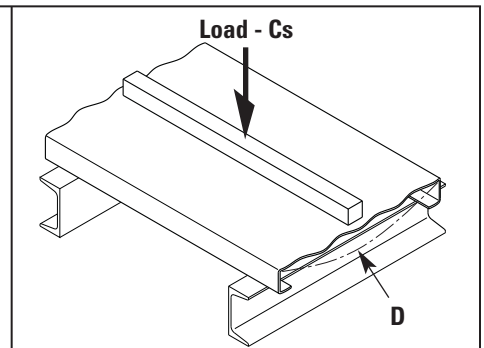

Figure 3
Concentrated Load (Cs)
applications to grating surface struts of all walkways/planks:
Maximum load (lb./ft.) permitted by flexural stress in grating strut, applied longitudinally to a 1 foot length of grating at midwidth.
Deflection (Ds) in all walkways/planks
Deflection (in.) corresponding to maximum concentrated strut load (Cs) permitted by flexural stress in grating strut, applied longitudinally to a 1 foot length of grating at midwidth.

General Load Information

Heavy Duty GRIP STRUT™ Walkways with Integrated Toeboards, Meeting OSHA Requirements

Heavy Duty GRIP STRUT Walkways* Availability

| Material | Thickness | Walkway Width | | |
|----------|-----------|---------------|-----|-----|
| | | 36" | 30" | 24" |
| Steel | 11 ga. | ✓ | ✓ | ✓ |
| | 10 ga. | ✓ | ✓ | ✓ |
| | 9 ga. | ✓ | ✓ | ✓ |

* Standard toeboard depth of 5".

Heavy Duty GRIP STRUT safety grating walkways, like Heavy Duty planks, offer additional strength for walkway applications with greater load requirements. Grating surface design is identical. The walkway difference is in the side channels, which are turned up as 5 inch toeboards, complying with OSHA requirements. Walkways offer all the slip-resistance and self-cleaning advantages of planks, and are available in the material and thickness combinations shown above.

Heavy Duty GRIP STRUT safety grating walkways are ideal for many types of applications. They are equally at home in process plants, refineries, grain elevators, conveyor walkways and large machines in paper mills. Allowable design load and deflection data are complete on pages 18 & 19.

They are combined with GRIP STRUT stair treads for a complete walkway design. For further information on stair treads, see page 23. The pre-formed, integral design of stair treads helps reduce the costs by saving not only material, but fabrication and detailing time as well.

Heavy Duty GRIP STRUT walkways incorporate 5 inch integral toeboards, complying with OSHA regulations (appropriate safety devices may also be necessary during use — consult applicable safety regulations). Canadian compliant (OH&S) designs are also available in some sizes.

Handrail brackets are available for application on Heavy Duty GRIP STRUT steel walkways. This is a valuable accessory for those projects where utilization of Heavy Duty GRIP STRUT steel walkway is desirable for its superior long spanability. And handrailing with handrail post on maximum eight foot center is required per OSHA. The handrail bracket eliminates unnecessary and costly substructure to support handrail post.

Splice plates (P-H-SP-U) are available for use with Heavy Duty GRIP STRUT steel walkways. Splice plates can help reduce costly material cuts and waste. The Splice Plates may be used at midspan conditions without reducing the load carrying capacity of the Heavy Duty GRIP STRUT walkway.

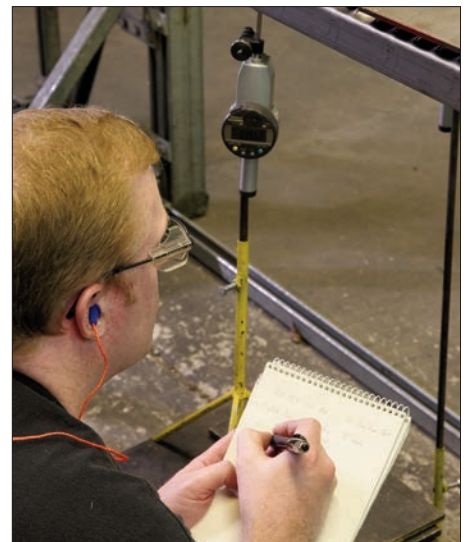
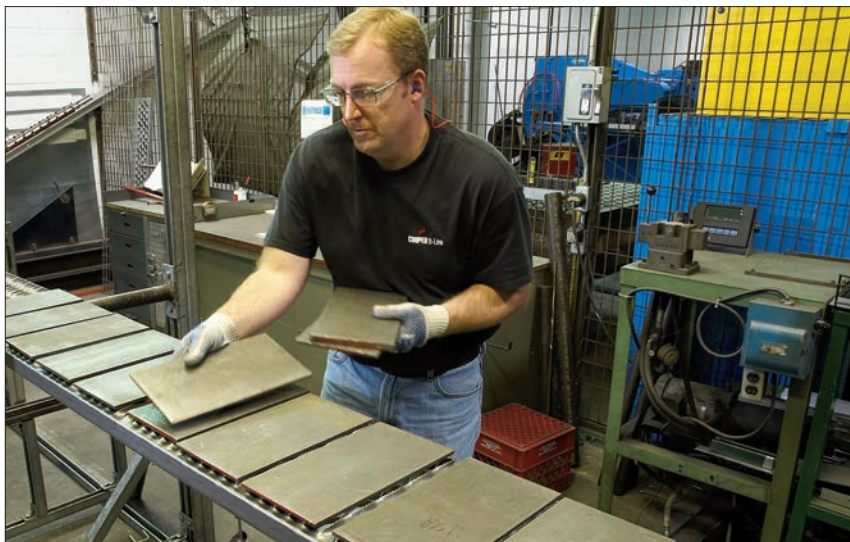

General Load Information

Heavy Duty GRIP STRUT™ Planks — Versatility of 9¹/₄" to 36" Widths for Single- or Multi-Width Platforms, to Fit Every Job Requirement — And Many O.E.M. Applications

Heavy Duty GRIP STRUT Planks* Availability

| Material | Thickness | Walkway Width | | | | |
|----------|-----------|---------------|----------------------------------|-----|----------------------------------|---------------------------------|
| | | 36" | 27 ³ / ₄ " | 24" | 13 ³ / ₄ " | 9 ¹ / ₄ " |
| Steel | 11 ga. | ✓ | ✓ | ✓ | ✓ | ✓ |
| | 10 ga. | ✓ | ✓ | ✓ | ✓ | ✓ |
| | 9 ga. | ✓ | ✓ | ✓ | ✓ | ✓ |

* All in depths of 2", 2¹/₂", 3" and 4".

Heavy Duty GRIP STRUT safety grating planks are ideal for all types and sizes of platform applications with design load requirements beyond the capacities of regular GRIP STRUT safety grating (fully described in GRIP STRUT safety grating catalog). Four depths and five widths, each in steel and aluminum alloy 5052, provide versatility of load capacity for greatest economy, as well as adequate strength without over design. Each width and side channel depth combination is available in material and thickness combinations as shown above.

All can be used for single-plank applications, or in multi-plank combinations for large-area platforms (see Multi-plank width chart, opposite page). One combination of width/depth/metal thickness is certain to meet your requirements with exceptional economy. For special job requirements, or the fine-tuned economies required by O.E.M. applications, other materials and many special fabricating services are available (see page 23).



Multi-Plank Width Comparison

0" clearance between planks

| | | | | |
|---|--|--|--|---|
| 15' | (19) 14'-7 ³ / ₄ " | (13) 14"-10 ³ / ₄ " | (6) 13"-9 ³ / ₄ " | (5) 15"-0" |
| | (18) 13'-10 ¹ / ₂ " | (12) 13"-9" | | |
| 12' | (17) 13'-1 ¹ / ₄ " | (11) 12"-7 ¹ / ₄ " | (5) 11"-6 ¹ / ₈ " | (4) 12"-0" |
| | (16) 12'-4" | | | |
| | (15) 11'-6 ³ / ₄ " | (9) 10"-3 ³ / ₄ " | | |
| | (14) 10'-9 ¹ / ₂ " | | | |
| | (13) 10'-0 ¹ / ₄ " | (8) 9"-2" | | |
| | (12) 9'-3" | | | |
| 9' | (11) 8'-5 ³ / ₄ " | (7) 8"-0 ¹ / ₄ " | (3) 9"-0" | |
| | (10) 7'-8 ¹ / ₂ " | | | |
| | (9) 6'-11 ¹ / ₄ " | (6) 6"-10 ¹ / ₂ " | | |
| | (8) 6'-2" | | | |
| 6' | (7) 5'-4 ³ / ₄ " | (5) 5"-8 ³ / ₄ " | (2) 6"-0" | |
| | (6) 4'-7 ¹ / ₂ " | | | (4) 4"-7" |
| | (5) 3'-10 ¹ / ₄ " | (3) 3"-5 ¹ / ₄ " | | |
| | (4) 3'-1" | | | |
| | (3) 2'-3 ³ / ₄ " | (2) 2"-3 ¹ / ₂ " | | |
| | (2) 1'-6 ¹ / ₂ " | | | (1) 2"-3 ⁵ / ₈ " |
| (1) 0'-9 ¹ / ₄ " | (1) 1"-1 ³ / ₄ " | (1) 3"-0" | | |
| 0' | 2-Diamond | 3-Diamond | 6-Diamond | 8-Diamond |

1/8" clearance between planks

| | | | | |
|---|--|--|---|--|
| 15' | (19) 14'-10" | (13) 15'-0 ¹ / ₄ " | (6) 13'-10 ³ / ₈ " | (5) 15'-0 ¹ / ₂ " |
| | (18) 14'-0 ⁵ / ₈ " | (12) 13'-10 ³ / ₈ " | | |
| 12' | (17) 13'-3 ¹ / ₄ " | (11) 12'-8 ¹ / ₂ " | (5) 11'-6 ⁵ / ₈ " | (4) 12'-0 ³ / ₈ " |
| | (16) 12'-5 ¹ / ₈ " | | | |
| | (15) 11'-8 ¹ / ₂ " | (9) 10'-4 ³ / ₄ " | | |
| | (14) 10'-10 ¹ / ₈ " | | | |
| | (13) 10'-1 ³ / ₄ " | (8) 9'-2 ⁷ / ₈ " | | |
| | (12) 9'-4 ³ / ₈ " | | | |
| 9' | (11) 8'-7" | (7) 8'-1" | (3) 9'-0 ¹ / ₄ " | |
| | (10) 7'-9 ⁵ / ₈ " | | | |
| | (9) 7'-0 ¹ / ₄ " | (6) 6'-11 ¹ / ₈ " | | |
| | (8) 6'-2 ⁷ / ₈ " | | | |
| 6' | (7) 5'-5 ¹ / ₂ " | (5) 4'-9 ¹ / ₄ " | (2) 6'-0 ¹ / ₈ " | |
| | (6) 4'-8 ¹ / ₈ " | | | (4) 4'-7 ³ / ₈ " |
| | (5) 3'-10 ³ / ₄ " | (3) 3'-5 ¹ / ₂ " | | |
| | (4) 3'-1 ³ / ₈ " | | | |
| | (3) 2'-4" | (2) 2'-3 ⁵ / ₈ " | | |
| | (2) 1'-6 ⁵ / ₈ " | | | (1) 2'-3 ⁵ / ₈ " |
| (1) 0'-9 ¹ / ₄ " | (1) 1'-1 ³ / ₄ " | (1) 3"-0" | | |
| 0' | 2-Diamond | 3-Diamond | 6-Diamond | 8-Diamond |

Heavy Duty GRIP STRUT™ Plank - Safe Loading Tables

2-Diamond Plank — 9 1/4" Width — "H" Series

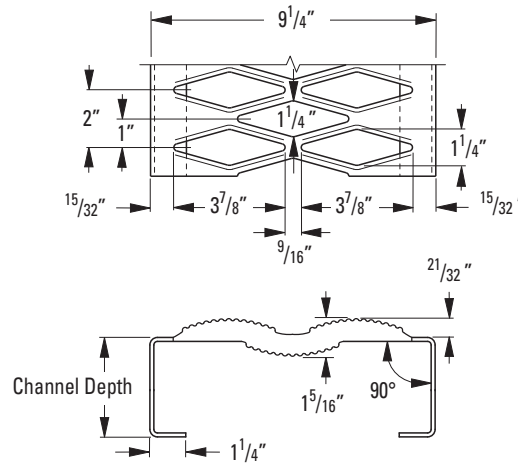

Plank Selection & Design Loads/Deflections

Allowable Loads and Deflections: U=Uniform Load (lb./ft.²) C= Concentrated Load (lb.) D=Deflection (in.)

| Material Gauge | Channel Depth in. (mm) | Weight lb./lin. ft. (kg/m) | Catalog Number | Span | | | | | | | | | | | | | | | | | |
|-----------------|------------------------|----------------------------|----------------|-------|-------|-------|-------|-------|-------|-------|-------|-------|-------|-------|-------|-------|-------|--------|--------|--------|------|
| | | | | 2'-0" | 2'-6" | 3'-0" | 3'-6" | 4'-0" | 4'-6" | 5'-0" | 5'-6" | 6'-0" | 6'-6" | 7'-0" | 7'-6" | 8'-0" | 9'-0" | 10'-0" | 11'-0" | 12'-0" | |
| Steel 11 ga. | 2" (38.1) | 6.6 (9.8) | H-22011 | U | 2413 | 1544 | 1027 | 788 | 629 | 476 | 385 | 319 | 270 | 228 | 196 | 172 | 150 | 119 | 98 | 81 | 67 |
| | | | | D | .05 | .08 | .11 | .15 | .19 | .24 | .30 | .35 | .41 | .47 | .54 | .62 | .69 | .85 | 1.04 | 1.24 | 1.45 |
| | | | | C | 1860 | 1488 | 1240 | 1063 | 930 | 827 | 744 | 677 | 620 | 572 | 531 | 496 | 465 | 413 | 372 | 338 | 310 |
| | | | | D | .04 | .06 | .09 | .12 | .15 | .19 | .24 | .28 | .33 | .38 | .44 | .49 | .55 | .68 | .81 | .98 | 1.16 |
| | 2 1/2" (63.5) | 7.0 (10.4) | H-22511 | U | 3657 | 2340 | 1625 | 1194 | 914 | 722 | 585 | 483 | 406 | 347 | 298 | 259 | 228 | 182 | 147 | 122 | 102 |
| | | | | D | .05 | .07 | .10 | .14 | .18 | .23 | .27 | .32 | .36 | .42 | .49 | .55 | .62 | .79 | .96 | 1.15 | 1.35 |
| | | | | C | 2820 | 2256 | 1880 | 1611 | 1410 | 1254 | 1128 | 1025 | 940 | 868 | 806 | 752 | 705 | 626 | 564 | 513 | 470 |
| | | | | D | .04 | .06 | .08 | .11 | .14 | .18 | .22 | .25 | .29 | .34 | .39 | .44 | .50 | .63 | .76 | .91 | 1.08 |
| | 3" (76.2) | 7.5 (11.1) | H-23011 | U | 3892 | 2490 | 1731 | 1272 | 974 | 767 | 623 | 515 | 431 | 368 | 319 | 276 | 242 | 193 | 154 | 130 | 109 |
| | | | | D | .04 | .06 | .08 | .11 | .15 | .18 | .22 | .26 | .30 | .34 | .39 | .44 | .48 | .58 | .68 | .80 | .95 |
| | | | | C | 3000 | 2400 | 2000 | 1715 | 1500 | 1333 | 1180 | 1091 | 1000 | 923 | 857 | 800 | 750 | 667 | 600 | 545 | 500 |
| | | | | D | .03 | .05 | .07 | .09 | .12 | .15 | .17 | .21 | .24 | .28 | .31 | .35 | .39 | .47 | .55 | .64 | .76 |
| 4" (101.6) | 8.3 (12.3) | H-24011 | U | 6382 | 4084 | 2837 | 2084 | 1598 | 1261 | 1022 | 844 | 707 | 606 | 522 | 455 | 400 | 315 | 256 | 211 | 176 | |
| | | | D | .03 | .05 | .07 | .09 | .12 | .14 | .17 | .20 | .23 | .27 | .31 | .35 | .39 | .47 | .56 | .66 | .78 | |
| | | | C | 4920 | 3936 | 3280 | 2812 | 2460 | 2187 | 1968 | 1789 | 1640 | 1514 | 1406 | 1312 | 1230 | 1094 | 935 | 895 | 820 | |
| | | | D | .03 | .04 | .06 | .07 | .09 | .11 | .14 | .16 | .19 | .22 | .25 | .28 | .31 | .38 | .45 | .53 | .63 | |
| Steel 10 ga. | 2" (50.8) | 7.4 (11.0) | H-22010 | U | 2681 | 1716 | 1141 | 876 | 699 | 529 | 428 | 354 | 300 | 253 | 218 | 191 | 167 | 132 | 109 | 90 | 74 |
| | | | | D | .05 | .08 | .11 | .15 | .19 | .24 | .30 | .35 | .41 | .47 | .54 | .62 | .69 | .85 | 1.04 | 1.24 | 1.45 |
| | | | | C | 2067 | 1653 | 1378 | 1181 | 1033 | 919 | 827 | 752 | 689 | 636 | 590 | 551 | 517 | 459 | 413 | 376 | 344 |
| | | | | D | .04 | .06 | .09 | .12 | .15 | .19 | .24 | .28 | .33 | .38 | .44 | .49 | .55 | .68 | .81 | .96 | 1.16 |
| | 2 1/2" (63.5) | 7.9 (11.7) | H-22510 | U | 4063 | 2600 | 1806 | 1327 | 1016 | 802 | 650 | 537 | 451 | 385 | 331 | 288 | 253 | 202 | 163 | 136 | 113 |
| | | | | D | .05 | .07 | .10 | .14 | .18 | .23 | .27 | .32 | .36 | .42 | .49 | .55 | .62 | .79 | .96 | 1.15 | 1.35 |
| | | | | C | 3133 | 2507 | 2089 | 1790 | 1567 | 1393 | 1253 | 1139 | 1044 | 964 | 895 | 836 | 783 | 696 | 627 | 570 | 522 |
| | | | | D | .04 | .06 | .08 | .12 | .14 | .18 | .22 | .25 | .29 | .34 | .39 | .44 | .50 | .63 | .76 | .91 | 1.08 |
| | 3" (76.2) | 8.4 (12.5) | H-23010 | U | 4324 | 2767 | 1923 | 1413 | 1082 | 852 | 692 | 572 | 479 | 409 | 354 | 307 | 269 | 214 | 171 | 144 | 121 |
| | | | | D | .04 | .06 | .08 | .11 | .15 | .18 | .22 | .26 | .30 | .34 | .39 | .44 | .48 | .58 | .68 | .80 | .95 |
| | | | | C | 3333 | 2667 | 2222 | 1905 | 1667 | 1481 | 1311 | 1212 | 1111 | 1026 | 952 | 889 | 833 | 741 | 667 | 606 | 556 |
| | | | | D | .03 | .05 | .07 | .09 | .12 | .15 | .17 | .21 | .24 | .28 | .31 | .35 | .39 | .47 | .55 | .64 | .76 |
| 4" (101.6) | 10.3 (15.3) | H-24010 | U | 7091 | 4538 | 3152 | 2316 | 1775 | 1401 | 1136 | 938 | 786 | 673 | 580 | 506 | 444 | 350 | 284 | 234 | 195 | |
| | | | D | .03 | .05 | .07 | .09 | .12 | .14 | .17 | .20 | .23 | .27 | .31 | .35 | .39 | .47 | .56 | .66 | .78 | |
| | | | C | 5467 | 4373 | 3644 | 3124 | 2733 | 2430 | 2187 | 1988 | 1822 | 1682 | 1562 | 1458 | 1367 | 1215 | 1039 | 994 | 911 | |
| | | | D | .03 | .04 | .06 | .07 | .09 | .11 | .14 | .16 | .19 | .22 | .25 | .28 | .31 | .38 | .45 | .53 | .63 | |

Heavy Duty GRIP STRUT™ Plank - Safe Loading Tables

2-Diamond Plank — 9¹/₄" Width — "H" Series cont.

Plank Selection & Design Loads/Deflections

Allowable Loads and Deflections: U=Uniform Load (lb./ft.²) C= Concentrated Load (lb.) D=Deflection (in.)

| Material Gauge | Channel Depth in. (mm) | Weight lb./lin. ft (kg/m) | Catalog Number | | Span | | | | | | | | | | | | | | | | |
|----------------|--|---------------------------|----------------|---|-------|-------|-------|-------|-------|-------|-------|-------|-------|-------|-------|-------|-------|-------|--------|--------|--------|
| | | | | | 2'-0" | 2'-6" | 3'-0" | 3'-6" | 4'-0" | 4'-6" | 5'-0" | 5'-6" | 6'-0" | 6'-6" | 7'-0" | 7'-6" | 8'-0" | 9'-0" | 10'-0" | 11'-0" | 12'-0" |
| Steel 9 ga. | 2" (38.1) | 8.3 (12.3) | H-22009 | U | 2949 | 1888 | 1255 | 964 | 769 | 582 | 471 | 389 | 330 | 278 | 240 | 210 | 184 | 145 | 120 | 96 | 81 |
| | | | | D | .05 | .08 | .11 | .15 | .19 | .24 | .30 | .35 | .41 | .47 | .54 | .62 | .69 | .85 | 1.04 | 1.24 | 1.45 |
| | | | | C | 2274 | 1618 | 1516 | 1299 | 1136 | 1011 | 910 | 827 | 758 | 700 | 649 | 606 | 569 | 505 | 454 | 414 | 378 |
| | 2 ¹ / ₂ " (63.5) | 8.8 (13.1) | H-22509 | U | 4469 | 2860 | 1987 | 1460 | 1118 | 882 | 715 | 591 | 496 | 424 | 364 | 317 | 278 | 222 | 179 | 150 | 124 |
| | | | | D | .05 | .07 | .10 | .14 | .18 | .23 | .27 | .32 | .36 | .42 | .49 | .55 | .62 | .79 | .96 | 1.15 | 1.35 |
| | | | | C | 3446 | 2758 | 2298 | 1969 | 1724 | 1532 | 1378 | 1253 | 1148 | 1060 | 985 | 920 | 861 | 766 | 690 | 627 | 574 |
| | 3" (76.2) | 9.3 (13.8) | H-23009 | U | 4756 | 3044 | 2115 | 1554 | 1190 | 937 | 761 | 629 | 527 | 450 | 389 | 338 | 296 | 235 | 188 | 158 | 133 |
| | | | | D | .04 | .06 | .08 | .11 | .15 | .18 | .22 | .26 | .30 | .34 | .39 | .44 | .48 | .58 | .68 | .80 | .95 |
| | | | | C | 3666 | 2934 | 2444 | 2096 | 1834 | 1629 | 1442 | 1333 | 1222 | 1129 | 1047 | 978 | 916 | 815 | 734 | 667 | 612 |
| | 4" (101.6) | 10.3 (15.3) | H-24009 | U | 7800 | 4992 | 3467 | 2548 | 1953 | 1541 | 1250 | 1032 | 865 | 740 | 638 | 557 | 488 | 385 | 312 | 257 | 215 |
| | | | | D | .03 | .05 | .07 | .09 | .12 | .14 | .17 | .20 | .23 | .27 | .31 | .35 | .39 | .47 | .56 | .66 | .78 |
| | | | | C | 6014 | 4810 | 4008 | 3436 | 3006 | 2673 | 2406 | 2187 | 2004 | 1850 | 1718 | 1604 | 1504 | 1337 | 1143 | 1093 | 1002 |
| | | | | D | .03 | .04 | .06 | .07 | .09 | .11 | .14 | .16 | .19 | .22 | .25 | .28 | .31 | .38 | .45 | .53 | .63 |

Strut Concentrated - Loads/Deflections⁽²⁾

| Plank Width | Thickness | Concentrated C _s (lb./ft.) | |
|---------------------------------|------------------|---------------------------------------|--------------|
| | | Serrated | Non-Serrated |
| 9 ¹ / ₄ " | 11 ga. Steel | 1741 | 1985 |
| | 10 ga. Steel | 2004 | 2283 |
| | 9 ga. Steel | 2281 | 2594 |
| | Deflection (in.) | 0.01 | 0.01 |

C_s = Allowable Concentrated Load per ft. of length at mid-width (lb./ft.)
 (2) See "General Load information", page 4, for explanation of design load deflection conditions.

Strut Uniform - Loads/Deflections⁽²⁾

| Plank Width | Thickness | Concentrated U (lb./ft.²) | |
|---------------------------------|------------------|---------------------------|--------------|
| | | Serrated | Non-Serrated |
| 9 ¹ / ₄ " | 11 ga. Steel | 4516 | 5153 |
| | 10 ga. Steel | 5201 | 5925 |
| | 9 ga. Steel | 5917 | 6731 |
| | Deflection (in.) | 0.01 | 0.01 |

U = Allowable Uniform Load (lb./ft.²)
 (2) See "General Load information", page 4, for explanation of design load deflection conditions.

Heavy Duty GRIP STRUT™ Plank - Safe Loading Tables

3-Diamond Plank — 13³/₄" Width — "H" Series

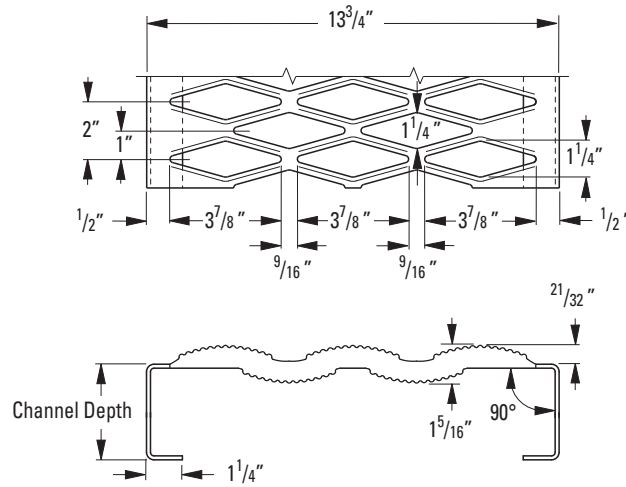

Plank Selection & Design Loads/Deflections

Allowable Loads and Deflections: U=Uniform Load (lb./ft.²) C= Concentrated Load (lb.) D=Deflection (in.)

| Material Gauge | Channel Depth in. (mm) | Weight lb./lin. ft. (kg/m) | Catalog Number | Span | | | | | | | | | | | | | | | | | |
|-----------------|------------------------|----------------------------|----------------|-------|-------|-------|-------|-------|-------|-------|-------|-------|-------|-------|-------|-------|-------|--------|--------|--------|------|
| | | | | 2'-0" | 2'-6" | 3'-0" | 3'-6" | 4'-0" | 4'-6" | 5'-0" | 5'-6" | 6'-0" | 6'-6" | 7'-0" | 7'-6" | 8'-0" | 9'-0" | 10'-0" | 11'-0" | 12'-0" | |
| Steel 11 ga. | 2" (38.1) | 8.5 (12.6) | H-32011 | U | 1624 | 1039 | 721 | 530 | 405 | 320 | 259 | 214 | 182 | 153 | 132 | 115 | 102 | 80 | 66 | 54 | 45 |
| | | | | D | .05 | .08 | .11 | .15 | .19 | .24 | .30 | .35 | .41 | .47 | .54 | .62 | .69 | .85 | 1.04 | 1.24 | 1.45 |
| | | | | C | 1860 | 1488 | 1240 | 1063 | 930 | 827 | 744 | 677 | 620 | 572 | 531 | 496 | 465 | 413 | 372 | 338 | 310 |
| | | | | D | .04 | .06 | .09 | .12 | .15 | .19 | .24 | .28 | .33 | .38 | .44 | .49 | .55 | .68 | .81 | .98 | 1.16 |
| | 2 1/2" (63.5) | 8.9 (13.2) | H-32511 | U | 2460 | 1615 | 1093 | 804 | 615 | 485 | 393 | 325 | 274 | 233 | 201 | 175 | 153 | 122 | 99 | 83 | 68 |
| | | | | D | .05 | .07 | .10 | .14 | .18 | .23 | .27 | .32 | .36 | .42 | .49 | .55 | .62 | .79 | .96 | 1.15 | 1.35 |
| | | | | C | 2820 | 2256 | 1880 | 1611 | 1410 | 1254 | 1128 | 1025 | 940 | 868 | 806 | 752 | 705 | 626 | 564 | 513 | 470 |
| | | | | D | .04 | .06 | .08 | .11 | .14 | .18 | .22 | .25 | .29 | .34 | .39 | .44 | .50 | .63 | .76 | .91 | 1.08 |
| | 3" (76.2) | 9.3 (13.8) | H-33011 | U | 2618 | 1676 | 1164 | 855 | 655 | 516 | 419 | 347 | 290 | 248 | 214 | 186 | 163 | 130 | 104 | 87 | 73 |
| | | | | D | .04 | .06 | .08 | .11 | .15 | .18 | .22 | .26 | .30 | .34 | .39 | .44 | .48 | .58 | .68 | .80 | .95 |
| | | | | C | 3000 | 2400 | 2000 | 1715 | 1500 | 1333 | 1180 | 1091 | 1000 | 923 | 857 | 800 | 750 | 667 | 600 | 545 | 500 |
| | | | | D | .03 | .05 | .07 | .09 | .12 | .15 | .17 | .21 | .24 | .28 | .31 | .35 | .39 | .47 | .55 | .64 | .76 |
| 4" (101.6) | 10.1 (15.0) | H-34011 | U | 4293 | 2748 | 1909 | 1402 | 1075 | 849 | 689 | 568 | 476 | 408 | 351 | 306 | 268 | 212 | 172 | 141 | 118 | |
| | | | D | .03 | .05 | .07 | .09 | .12 | .14 | .17 | .20 | .23 | .27 | .31 | .35 | .39 | .47 | .56 | .66 | .78 | |
| | | | C | 4920 | 3936 | 3280 | 2812 | 2460 | 2187 | 1968 | 1789 | 1640 | 1514 | 1406 | 1312 | 1230 | 1094 | 935 | 895 | 820 | |
| | | | D | .03 | .04 | .06 | .07 | .09 | .11 | .14 | .16 | .19 | .22 | .25 | .28 | .31 | .38 | .45 | .53 | .63 | |
| Steel 10 ga. | 2" (50.8) | 9.5 (14.1) | H-32010 | U | 1804 | 1154 | 801 | 589 | 450 | 356 | 288 | 238 | 202 | 170 | 147 | 128 | 113 | 89 | 73 | 60 | 50 |
| | | | | D | .05 | .08 | .11 | .15 | .19 | .24 | .30 | .35 | .41 | .47 | .54 | .62 | .69 | .85 | 1.04 | 1.24 | 1.45 |
| | | | | C | 2067 | 1653 | 1378 | 1181 | 1033 | 919 | 827 | 752 | 689 | 636 | 590 | 551 | 517 | 459 | 413 | 376 | 344 |
| | | | | D | .04 | .06 | .09 | .12 | .15 | .19 | .24 | .28 | .33 | .38 | .44 | .49 | .55 | .68 | .81 | .98 | 1.16 |
| | 2 1/2" (63.5) | 10.0 (14.9) | H-32510 | U | 2733 | 1794 | 1214 | 893 | 683 | 539 | 437 | 361 | 304 | 259 | 223 | 194 | 170 | 136 | 110 | 92 | 76 |
| | | | | D | .05 | .07 | .10 | .14 | .18 | .23 | .27 | .32 | .36 | .42 | .49 | .55 | .62 | .79 | .96 | 1.15 | 1.35 |
| | | | | C | 3133 | 2507 | 2089 | 1790 | 1567 | 1393 | 1253 | 1139 | 1044 | 964 | 895 | 836 | 783 | 696 | 627 | 570 | 522 |
| | | | | D | .04 | .06 | .08 | .11 | .14 | .18 | .22 | .25 | .29 | .34 | .39 | .44 | .50 | .63 | .76 | .91 | 1.08 |
| | 3" (76.2) | 10.5 (15.6) | H-33010 | U | 2909 | 1862 | 1293 | 950 | 728 | 573 | 466 | 385 | 322 | 275 | 238 | 207 | 181 | 144 | 115 | 97 | 81 |
| | | | | D | .04 | .06 | .08 | .11 | .15 | .18 | .22 | .26 | .30 | .34 | .39 | .44 | .48 | .58 | .68 | .80 | .95 |
| | | | | C | 3333 | 2667 | 2222 | 1905 | 1667 | 1481 | 1311 | 1212 | 1111 | 1026 | 952 | 889 | 833 | 741 | 667 | 606 | 556 |
| | | | | D | .03 | .05 | .07 | .09 | .12 | .15 | .17 | .21 | .24 | .28 | .31 | .35 | .39 | .47 | .55 | .64 | .xx |
| 4" (101.6) | 11.4 (16.9) | H-34010 | U | 4770 | 3053 | 2121 | 1558 | 1194 | 943 | 765 | 631 | 529 | 453 | 390 | 340 | 298 | 236 | 191 | 157 | 13x | |
| | | | D | .03 | .05 | .07 | .09 | .12 | .14 | .17 | .20 | .23 | .27 | .31 | .35 | .39 | .47 | .56 | .66 | .78 | |
| | | | C | 5467 | 4373 | 3644 | 3124 | 2733 | 2430 | 2187 | 1988 | 1822 | 1682 | 1562 | 1458 | 1367 | 1215 | 1039 | 994 | 911 | |
| | | | D | .03 | .04 | .06 | .07 | .09 | .11 | .14 | .16 | .19 | .22 | .25 | .28 | .31 | .38 | .46 | .53 | .63 | |

Heavy Duty GRIP STRUT™ Plank - Safe Loading Tables

3-Diamond Plank — 13³/₄" Width — "H" Series cont.

Plank Selection & Design Loads/Deflections

Allowable Loads and Deflections: U=Uniform Load (lb./ft.²) C= Concentrated Load (lb.) D=Deflection (in.)

| Material Gauge | Channel Depth in. (mm) | Weight lb./lin. ft (kg/m) | Catalog Number | | Span | | | | | | | | | | | | | | | | |
|----------------|------------------------|---------------------------|----------------|---|-------|-------|-------|-------|-------|-------|-------|-------|-------|-------|-------|-------|-------|-------|--------|--------|--------|
| | | | | | 2'-0" | 2'-6" | 3'-0" | 3'-6" | 4'-0" | 4'-6" | 5'-0" | 5'-6" | 6'-0" | 6'-6" | 7'-0" | 7'-6" | 8'-0" | 9'-0" | 10'-0" | 11'-0" | 12'-0" |
| Steel 9 ga. | 2" (38.1) | 10.6 (15.8) | H-32009 | U | 1984 | 1269 | 881 | 648 | 495 | 392 | 317 | 262 | 222 | 187 | 162 | 141 | 124 | 98 | 80 | 66 | 55 |
| | | | | D | .05 | .06 | .11 | .15 | .19 | .24 | .30 | .35 | .41 | .47 | .54 | .62 | .69 | .85 | 1.04 | 1.24 | 1.45 |
| | | | | C | 2274 | 1818 | 1516 | 1299 | 1136 | 1011 | 910 | 827 | 758 | 700 | 649 | 606 | 569 | 505 | 454 | 414 | 378 |
| | 2 1/2" (63.5) | 11.1 (16.5) | H-32509 | U | 3006 | 1973 | 1335 | 982 | 751 | 593 | 481 | 397 | 334 | 285 | 245 | 213 | 187 | 150 | 121 | 101 | 84 |
| | | | | D | .05 | .07 | .10 | .14 | .18 | .23 | .27 | .32 | .36 | .42 | .49 | .55 | .62 | .79 | .96 | 1.15 | 1.35 |
| | | | | C | 3446 | 2758 | 2298 | 1969 | 1724 | 1532 | 1378 | 1253 | 1148 | 1060 | 985 | 920 | 861 | 766 | 690 | 627 | 574 |
| | 3" (76.2) | 11.6 (17.2) | H-33009 | U | 3200 | 2048 | 1422 | 1045 | 801 | 630 | 513 | 424 | 354 | 303 | 262 | 228 | 199 | 158 | 127 | 107 | 89 |
| | | | | D | .04 | .06 | .08 | .11 | .15 | .18 | .22 | .26 | .30 | .34 | .39 | .44 | .48 | .58 | .68 | .80 | .95 |
| | | | | C | 3666 | 2934 | 2444 | 2096 | 1834 | 1629 | 1442 | 1333 | 1222 | 1129 | 1047 | 978 | 916 | 815 | 734 | 667 | 612 |
| | 4" (101.6) | 12.7 (18.9) | H-34009 | U | 5247 | 3358 | 2333 | 1714 | 1313 | 1037 | 842 | 694 | 582 | 498 | 429 | 374 | 328 | 260 | 210 | 173 | 144 |
| | | | | D | .03 | .05 | .07 | .09 | .12 | .14 | .17 | .20 | .23 | .27 | .31 | .35 | .39 | .47 | .56 | .66 | .78 |
| | | | | C | 6014 | 4810 | 4008 | 3436 | 3006 | 2673 | 2406 | 2187 | 2004 | 1850 | 1718 | 1604 | 1504 | 1337 | 1143 | 1093 | 1002 |
| | | | | D | .03 | .04 | .06 | .07 | .09 | .11 | .14 | .16 | .19 | .22 | .25 | .28 | .31 | .38 | .45 | .53 | .63 |

Strut Concentrated - Loads/Deflections⁽²⁾

| Plank Width | Thickness | Concentrated C _s (lb./ft.) | |
|----------------------------------|------------------|---------------------------------------|--------------|
| | | Serrated | Non-Serrated |
| 13 ³ / ₄ " | 11 ga. Steel | 1171 | 1336 |
| | 10 ga. Steel | 1348 | 1536 |
| | 9 ga. Steel | 1534 | 1745 |
| | Deflection (in.) | 0.02 | 0.02 |

C_s = Allowable Concentrated Load per ft. of length at mid-width (lb./ft.)
 (2) See "General Load information", page 4, for explanation of design load deflection conditions.

Strut Uniform - Loads/Deflections⁽²⁾

| Plank Width | Thickness | Concentrated U (lb./ft.²) | |
|----------------------------------|------------------|---------------------------|--------------|
| | | Serrated | Non-Serrated |
| 13 ³ / ₄ " | 11 ga. Steel | 2044 | 2322 |
| | 10 ga. Steel | 2354 | 2681 |
| | 9 ga. Steel | 2678 | 3046 |
| | Deflection (in.) | 0.03 | 0.03 |

U = Allowable Uniform Load (lb./ft.²)
 (2) See "General Load information", page 4, for explanation of design load deflection conditions.

Heavy Duty GRIP STRUT™ Plank - Safe Loading Tables

5-Diamond Plank — 23¹/₄" Width — "H" Series

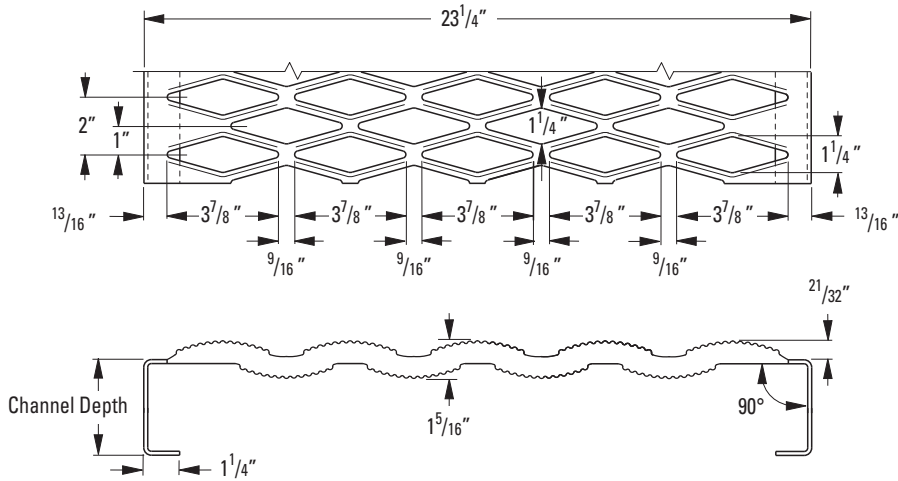

Plank Selection & Design Loads/Deflections

Allowable Loads and Deflections: U=Uniform Load (lb./ft.²) C= Concentrated Load (lb.) D=Deflection (in.)

| Material Gauge | Channel Depth in. (mm) | Weight lb./lin. ft. (kg/m) | Catalog Number | Span | | | | | | | | | | | | | | | | | |
|-----------------|------------------------|----------------------------|----------------|-------|-------|-------|-------|-------|-------|-------|-------|-------|-------|-------|-------|-------|-------|--------|--------|--------|------|
| | | | | 2'-0" | 2'-6" | 3'-0" | 3'-6" | 4'-0" | 4'-6" | 5'-0" | 5'-6" | 6'-0" | 6'-6" | 7'-0" | 7'-6" | 8'-0" | 9'-0" | 10'-0" | 11'-0" | 12'-0" | |
| Steel 11 ga. | 2" (38.1) | 12.7 (18.9) | H-52011 | U | 930 | 595 | 413 | 304 | 232 | 184 | 149 | 123 | 104 | 88 | 76 | 66 | 58 | 46 | 38 | 31 | 26 |
| | | | | D | .04 | .06 | .08 | .11 | .14 | .18 | .22 | .25 | .29 | .34 | .39 | .44 | .50 | .63 | .76 | .91 | 1.08 |
| | | | | C | 1860 | 1488 | 1240 | 1063 | 930 | 827 | 744 | 677 | 620 | 572 | 531 | 496 | 465 | 413 | 372 | 338 | 310 |
| | | | | D | .04 | .06 | .09 | .12 | .15 | .19 | .24 | .28 | .33 | .38 | .44 | .49 | .55 | .68 | .81 | .98 | 1.16 |
| | 2 1/2" (63.5) | 13.1 (19.5) | H-52511 | U | 1409 | 925 | 626 | 460 | 352 | 278 | 225 | 186 | 157 | 134 | 115 | 100 | 88 | 70 | 57 | 47 | 39 |
| | | | | D | .03 | .05 | .07 | .09 | .12 | .15 | .17 | .21 | .24 | .28 | .31 | .35 | .39 | .47 | .55 | .64 | .76 |
| | | | | C | 2820 | 2256 | 1880 | 1611 | 1410 | 1254 | 1128 | 1025 | 940 | 868 | 806 | 752 | 705 | 626 | 564 | 513 | 470 |
| | | | | D | .04 | .06 | .08 | .11 | .14 | .18 | .22 | .25 | .29 | .34 | .39 | .44 | .50 | .63 | .76 | .91 | 1.06 |
| | 3" (76.2) | 13.6 (20.2) | H-53011 | U | 1547 | 989 | 687 | 504 | 387 | 305 | 247 | 204 | 170 | 146 | 125 | 110 | 96 | 76 | 60 | 51 | 42 |
| | | | | D | .04 | .06 | .08 | .11 | .15 | .18 | .22 | .26 | .30 | .34 | .39 | .44 | .48 | .58 | .68 | .80 | .95 |
| | | | | C | 3000 | 2400 | 2000 | 1715 | 1500 | 1333 | 1180 | 1091 | 1000 | 923 | 857 | 800 | 750 | 667 | 600 | 545 | 500 |
| | | | | D | .03 | .05 | .07 | .09 | .12 | .15 | .17 | .21 | .24 | .28 | .31 | .35 | .39 | .47 | .55 | .64 | .76 |
| 4" (101.6) | 14.4 (21.4) | H-54011 | U | 2538 | 1624 | 1129 | 828 | 635 | 502 | 406 | 334 | 280 | 240 | 207 | 181 | 158 | 125 | 101 | 84 | 70 | |
| | | | D | .03 | .05 | .07 | .09 | .12 | .14 | .17 | .20 | .23 | .27 | .31 | .35 | .39 | .47 | .56 | .66 | .78 | |
| | | | C | 4920 | 3936 | 3280 | 2812 | 2460 | 2187 | 1968 | 1789 | 1640 | 1514 | 1406 | 1312 | 1230 | 1094 | 935 | 895 | 820 | |
| | | | D | .03 | .04 | .06 | .07 | .09 | .11 | .14 | .16 | .19 | .22 | .25 | .28 | .31 | .38 | .45 | .53 | .63 | |
| Steel 10 ga. | 2" (50.8) | 14.4 (21.4) | H-52010 | U | 1034 | 661 | 459 | 337 | 258 | 204 | 165 | 136 | 116 | 97 | 84 | 73 | 65 | 51 | 42 | 34 | 29 |
| | | | | D | .04 | .06 | .08 | .11 | .14 | .18 | .22 | .25 | .29 | .34 | .39 | .44 | .50 | .63 | .76 | .91 | 1.08 |
| | | | | C | 2067 | 1653 | 1378 | 1181 | 1033 | 919 | 827 | 752 | 689 | 636 | 590 | 551 | 517 | 459 | 413 | 376 | 344 |
| | | | | D | .04 | .06 | .09 | .12 | .15 | .19 | .24 | .28 | .33 | .38 | .44 | .49 | .55 | .68 | .81 | .98 | 1.16 |
| | 2 1/2" (63.5) | 14.8 (22.0) | H-52510 | U | 1617 | 1034 | 718 | 528 | 404 | 319 | 259 | 214 | 180 | 153 | 132 | 115 | 101 | 81 | 65 | 54 | 45 |
| | | | | D | .05 | .07 | .10 | .14 | .18 | .23 | .27 | .32 | .36 | .42 | .49 | .55 | .62 | .79 | .96 | 1.15 | 1.35 |
| | | | | C | 3133 | 2507 | 2089 | 1790 | 1567 | 1393 | 1253 | 1139 | 1044 | 964 | 895 | 836 | 783 | 696 | 627 | 570 | 522 |
| | | | | D | .04 | .06 | .08 | .11 | .14 | .18 | .22 | .25 | .29 | .34 | .39 | .44 | .50 | .63 | .76 | .91 | 1.08 |
| | 3" (76.2) | 15.4 (22.9) | H-53010 | U | 1720 | 1101 | 765 | 562 | 430 | 339 | 276 | 228 | 190 | 163 | 141 | 122 | 107 | 85 | 68 | 57 | 48 |
| | | | | D | .04 | .06 | .08 | .11 | .15 | .18 | .22 | .26 | .30 | .34 | .39 | .44 | .48 | .58 | .68 | .80 | .95 |
| | | | | C | 3333 | 2667 | 2222 | 1905 | 1667 | 1481 | 1311 | 1212 | 1111 | 1026 | 952 | 889 | 833 | 741 | 667 | 606 | 556 |
| | | | | D | .03 | .05 | .07 | .09 | .11 | .12 | .17 | .21 | .24 | .28 | .31 | .35 | .39 | .47 | .55 | .64 | .76 |
| 4" (101.6) | 16.4 (24.4) | H-54010 | U | 2821 | 1805 | 1254 | 921 | 706 | 557 | 452 | 373 | 312 | 268 | 231 | 201 | 177 | 139 | 113 | 93 | 77 | |
| | | | D | .03 | .05 | .07 | .09 | .12 | .14 | .17 | .20 | .23 | .27 | .31 | .35 | .39 | .47 | .56 | .66 | .76 | |
| | | | C | 5467 | 4373 | 3644 | 3124 | 2733 | 2430 | 2187 | 1988 | 1822 | 1682 | 1562 | 1458 | 1367 | 1215 | 1039 | 994 | 911 | |
| | | | D | .03 | .04 | .05 | .07 | .09 | .11 | .14 | .16 | .19 | .22 | .25 | .28 | .31 | .38 | .45 | .53 | .63 | |

Heavy Duty GRIP STRUT™ Plank - Safe Loading Tables

5-Diamond Plank — 23¹/₄" Width — "H" Series cont.

Plank Selection & Design Loads/Deflections

Allowable Loads and Deflections: U=Uniform Load (lb./ft.²) C= Concentrated Load (lb.) D=Deflection (in.)

| Material Gauge | Channel Depth in. (mm) | Weight lb./lin. ft (kg/m) | Catalog Number | | Span | | | | | | | | | | | | | | | | |
|----------------|--|---------------------------|----------------|------|-------|-------|-------|-------|-------|-------|-------|-------|-------|-------|-------|-------|-------|-------|--------|--------|--------|
| | | | | | 2'-0" | 2'-6" | 3'-0" | 3'-6" | 4'-0" | 4'-6" | 5'-0" | 5'-6" | 6'-0" | 6'-6" | 7'-0" | 7'-6" | 8'-0" | 9'-0" | 10'-0" | 11'-0" | 12'-0" |
| Steel 9 ga. | 2" (38.1) | 16.1 (23.9) | H-52009 | U | 1137 | 727 | 505 | 371 | 284 | 224 | 182 | 150 | 127 | 107 | 93 | 81 | 71 | 56 | 46 | 38 | 32 |
| | | | | D | .04 | .06 | .08 | .11 | .14 | .18 | .22 | .25 | .29 | .34 | .39 | .44 | .50 | .63 | .76 | .91 | 1.08 |
| | | | | C | 2274 | 1818 | 1516 | 1299 | 1136 | 1011 | 910 | 827 | 758 | 700 | 649 | 606 | 569 | 505 | 454 | 414 | 378 |
| | | | | D | .04 | .06 | .09 | .12 | .15 | .19 | .24 | .28 | .33 | .38 | .44 | .49 | .55 | .68 | .81 | .98 | 1.16 |
| | 2 ¹ / ₂ " (63.5) | 16.7 (24.8) | H-52509 | U | 1778 | 1137 | 790 | 581 | 444 | 359 | 283 | 234 | 197 | 167 | 144 | 125 | 110 | 88 | 71 | 59 | 48 |
| | | | | D | .05 | .07 | .10 | .14 | .18 | .23 | .27 | .32 | .36 | .42 | .49 | .55 | .62 | .79 | .96 | 1.15 | 1.35 |
| | | | | C | 3446 | 2758 | 2298 | 1969 | 1724 | 1532 | 1378 | 1253 | 1148 | 1060 | 985 | 920 | 861 | 766 | 690 | 627 | 574 |
| | | | | D | .04 | .06 | .08 | .11 | .14 | .18 | .22 | .25 | .29 | .34 | .39 | .44 | .50 | .63 | .76 | .91 | 1.08 |
| | 3" (76.2) | 17.2 (25.6) | H-53009 | U | 1892 | 1211 | 841 | 618 | 472 | 372 | 302 | 249 | 209 | 178 | 155 | 133 | 116 | 93 | 74 | 62 | 53 |
| | | | | D | .04 | .06 | .08 | .11 | .15 | .18 | .22 | .26 | .30 | .34 | .39 | .44 | .48 | .58 | .68 | .80 | .95 |
| | | | | C | 3666 | 2934 | 2444 | 2096 | 1834 | 1629 | 1442 | 1333 | 1222 | 1129 | 1047 | 978 | 916 | 815 | 734 | 667 | 612 |
| | | | | D | .03 | .05 | .07 | .09 | .12 | .15 | .17 | .21 | .24 | .28 | .31 | .35 | .39 | .47 | .55 | .64 | .76 |
| 4" (101.6) | 18.3 (27.2) | H-54009 | U | 3103 | 1985 | 1380 | 1013 | 775 | 613 | 497 | 410 | 344 | 294 | 252 | 221 | 194 | 153 | 124 | 102 | 85 | |
| | | | D | .03 | .05 | .07 | .09 | .12 | .14 | .17 | .20 | .23 | .27 | .31 | .35 | .39 | .47 | .56 | .66 | .78 | |
| | | | C | 6014 | 4810 | 4008 | 3436 | 3006 | 2673 | 2406 | 2187 | 2004 | 1850 | 1718 | 1604 | 1504 | 1337 | 1143 | 1093 | 1002 | |
| | | | D | .03 | .04 | .06 | .07 | .09 | .11 | .14 | .16 | .19 | .22 | .25 | .28 | .31 | .38 | .45 | .53 | .63 | |

Strut Concentrated - Loads/Deflections⁽²⁾

| Plank Width | Thickness | Concentrated C _s (lb./ft.) | |
|----------------------------------|------------------|---------------------------------------|--------------|
| | | Serrated | Non-Serrated |
| 23 ¹ / ₄ " | 11 ga. Steel | 823 | 939 |
| | 10 ga. Steel | 941 | 1072 |
| | 9 ga. Steel | 1059 | 1205 |
| | Deflection (in.) | 0.08 | 0.07 |

C_s = Allowable Concentrated Load per ft. of length at mid-width (lb./ft.)

(2) See "General Load information", page 4, for explanation of design load deflection conditions.

Strut Uniform - Loads/Deflections⁽²⁾

| Plank Width | Thickness | Concentrated U (lb./ft.²) | |
|----------------------------------|------------------|---------------------------|--------------|
| | | Serrated | Non-Serrated |
| 23 ¹ / ₄ " | 11 ga. Steel | 850 | 969 |
| | 10 ga. Steel | 971 | 1106 |
| | 9 ga. Steel | 1093 | 1244 |
| | Deflection (in.) | 0.10 | 0.09 |

U = Allowable Uniform Load (lb./ft.²)

(2) See "General Load information", page 4, for explanation of design load deflection conditions.

Heavy Duty GRIP STRUT™ Plank - Safe Loading Tables

6-Diamond Plank — 27³/₄" Width — "H" Series

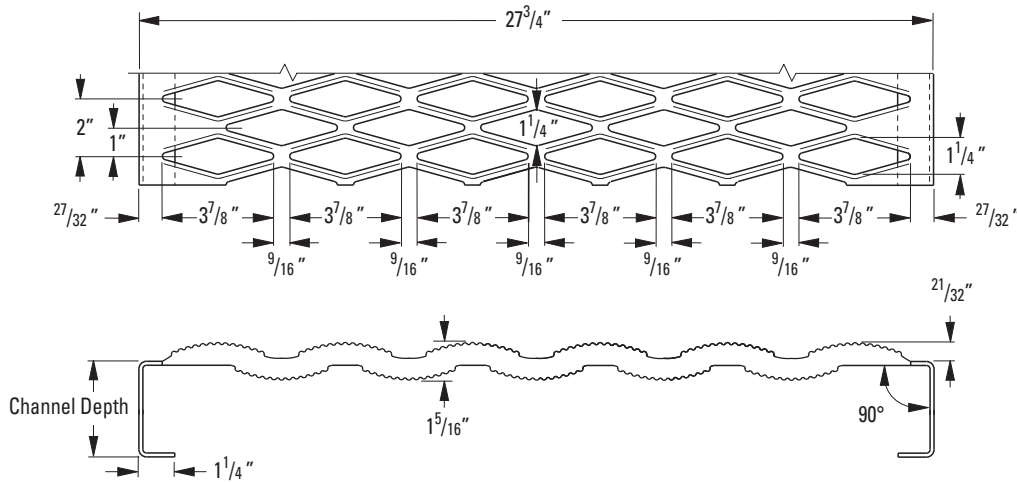

Plank Selection & Design Loads/Deflections

Allowable Loads and Deflections: U=Uniform Load (lb./ft.) C= Concentrated Load (lb.) D=Deflection (in.)

| Material Gauge | Channel Depth in. (mm) | Weight lb./lin. ft. (kg/m) | Catalog Number | Span | | | | | | | | | | | | | | | | | |
|-----------------|------------------------|----------------------------|----------------|-------|-------|-------|-------|-------|-------|-------|-------|-------|-------|-------|-------|-------|-------|--------|--------|--------|------|
| | | | | 2'-0" | 2'-6" | 3'-0" | 3'-6" | 4'-0" | 4'-6" | 5'-0" | 5'-6" | 6'-0" | 6'-6" | 7'-0" | 7'-6" | 8'-0" | 9'-0" | 10'-0" | 11'-0" | 12'-0" | |
| Steel 11 ga. | 2" (38.1) | 14.3 (21.3) | H-62011 | U | 830 | 530 | 368 | 271 | 206 | 163 | 132 | 108 | 93 | 78 | 67 | 59 | 51 | 40 | 34 | 27 | 22 |
| | | | | D | .05 | .08 | .11 | .15 | .19 | .24 | .30 | .35 | .41 | .47 | .54 | .62 | .69 | .85 | 1.04 | 1.24 | 1.45 |
| | | | | C | 1860 | 1488 | 1240 | 1063 | 930 | 827 | 744 | 677 | 620 | 572 | 531 | 496 | 465 | 413 | 372 | 338 | 310 |
| | | | | D | .04 | .06 | .09 | .12 | .15 | .19 | .24 | .28 | .33 | .38 | .44 | .49 | .55 | .68 | .81 | .98 | 1.16 |
| | 2 1/2" (63.5) | 14.7 (21.9) | H-62511 | U | 1258 | 805 | 559 | 410 | 313 | 247 | 201 | 166 | 139 | 119 | 102 | 88 | 78 | 61 | 49 | 42 | 35 |
| | | | | D | .05 | .07 | .10 | .14 | .18 | .23 | .27 | .32 | .36 | .42 | .49 | .55 | .62 | .79 | .96 | 1.15 | 1.35 |
| | | | | C | 2820 | 2256 | 1880 | 1611 | 1410 | 1254 | 1128 | 1025 | 940 | 868 | 806 | 752 | 705 | 626 | 564 | 513 | 470 |
| | | | | D | .04 | .06 | .08 | .11 | .14 | .18 | .22 | .25 | .29 | .34 | .39 | .44 | .50 | .63 | .76 | .91 | 1.08 |
| | 3" (76.2) | 15.2 (22.6) | H-63011 | U | 1338 | 855 | 594 | 436 | 335 | 264 | 214 | 176 | 147 | 126 | 108 | 95 | 83 | 66 | 52 | 44 | 36 |
| | | | | D | .04 | .06 | .08 | .11 | .15 | .18 | .22 | .26 | .30 | .34 | .39 | .44 | .48 | .58 | .68 | .80 | .95 |
| | | | | C | 3000 | 2400 | 2000 | 1715 | 1500 | 1333 | 1180 | 1091 | 1000 | 923 | 857 | 800 | 750 | 667 | 600 | 545 | 500 |
| | | | | D | .03 | .05 | .07 | .09 | .12 | .15 | .17 | .21 | .24 | .28 | .31 | .35 | .39 | .47 | .55 | .64 | .76 |
| 4" (101.6) | 16.0 (23.8) | H-64011 | U | 2234 | 1405 | 976 | 716 | 549 | 434 | 351 | 289 | 242 | 208 | 179 | 157 | 137 | 106 | 87 | 73 | 61 | |
| | | | D | .03 | .05 | .07 | .09 | .12 | .14 | .17 | .20 | .23 | .27 | .31 | .35 | .39 | .47 | .56 | .66 | .78 | |
| | | | C | 4920 | 3936 | 3280 | 2812 | 2460 | 2187 | 1968 | 1789 | 1640 | 1514 | 1406 | 1312 | 1230 | 1094 | 935 | 895 | 820 | |
| | | | D | .03 | .04 | .06 | .07 | .09 | .11 | .14 | .16 | .19 | .22 | .25 | .28 | .31 | .38 | .45 | .53 | .63 | |
| Steel 10 ga. | 2" (50.8) | 16.2 (24.1) | H-62010 | U | 923 | 590 | 410 | 301 | 230 | 182 | 147 | 122 | 103 | 87 | 75 | 66 | 58 | 46 | 37 | 31 | 25 |
| | | | | D | .05 | .08 | .11 | .15 | .19 | .24 | .30 | .35 | .41 | .47 | .54 | .62 | .69 | .85 | 1.04 | 1.24 | 1.45 |
| | | | | C | 2067 | 1653 | 1378 | 1181 | 1033 | 919 | 827 | 752 | 689 | 636 | 590 | 551 | 517 | 459 | 413 | 376 | 344 |
| | | | | D | .04 | .06 | .09 | .12 | .15 | .19 | .24 | .28 | .33 | .38 | .44 | .49 | .55 | .68 | .81 | .98 | 1.16 |
| | 2 1/2" (63.5) | 16.7 (24.8) | H-62510 | U | 1398 | 894 | 621 | 457 | 349 | 276 | 224 | 185 | 156 | 132 | 114 | 99 | 87 | 70 | 56 | 47 | 39 |
| | | | | D | .05 | .07 | .10 | .14 | .18 | .23 | .27 | .32 | .36 | .42 | .49 | .55 | .62 | .79 | .96 | 1.15 | 1.35 |
| | | | | C | 3133 | 2507 | 2089 | 1790 | 1567 | 1393 | 1253 | 1139 | 1044 | 964 | 895 | 836 | 783 | 696 | 627 | 570 | 522 |
| | | | | D | .04 | .06 | .08 | .11 | .14 | .18 | .22 | .25 | .29 | .34 | .39 | .44 | .50 | .63 | .76 | .91 | 1.08 |
| | 3" (76.2) | 17.2 (25.6) | H-63010 | U | 1488 | 952 | 662 | 486 | 372 | 293 | 239 | 197 | 164 | 141 | 122 | 106 | 93 | 74 | 59 | 49 | 42 |
| | | | | D | .04 | .06 | .08 | .11 | .15 | .18 | .22 | .26 | .30 | .34 | .39 | .44 | .48 | .58 | .68 | .80 | .95 |
| | | | | C | 3333 | 2667 | 2222 | 1905 | 1667 | 1481 | 1311 | 1212 | 1111 | 1026 | 952 | 889 | 833 | 741 | 667 | 606 | 556 |
| | | | | D | .03 | .05 | .07 | .09 | .12 | .15 | .17 | .21 | .24 | .28 | .31 | .35 | .39 | .47 | .55 | .64 | .76 |
| 4" (101.6) | 18.2 (27.1) | H-64010 | U | 2440 | 1561 | 1055 | 797 | 611 | 482 | 391 | 323 | 270 | 232 | 200 | 174 | 153 | 120 | 98 | 80 | 67 | |
| | | | D | .03 | .05 | .07 | .09 | .12 | .14 | .17 | .20 | .23 | .27 | .31 | .35 | .39 | .47 | .56 | .66 | .78 | |
| | | | C | 5467 | 4373 | 3644 | 3124 | 2733 | 2430 | 2187 | 1988 | 1822 | 1682 | 1562 | 1458 | 1367 | 1215 | 1039 | 994 | 911 | |
| | | | D | .03 | .04 | .06 | .07 | .09 | .11 | .14 | .16 | .19 | .22 | .25 | .28 | .31 | .38 | .45 | .53 | .63 | |

Heavy Duty GRIP STRUT™ Plank - Safe Loading Tables

6-Diamond Plank — 27³/₄" Width — "H" Series cont.

Plank Selection & Design Loads/Deflections

Allowable Loads and Deflections: U=Uniform Load (lb./ft.²) C= Concentrated Load (lb.) D=Deflection (in.)

| Material Gauge | Channel Depth in. (mm) | Weight lb./lin. ft (kg/m) | Catalog Number | | Span | | | | | | | | | | | | | | | | |
|----------------|------------------------|---------------------------|----------------|---|-------|-------|-------|-------|-------|-------|-------|-------|-------|-------|-------|-------|-------|-------|--------|--------|--------|
| | | | | | 2'-0" | 2'-6" | 3'-0" | 3'-6" | 4'-0" | 4'-6" | 5'-0" | 5'-6" | 6'-0" | 6'-6" | 7'-0" | 7'-6" | 8'-0" | 9'-0" | 10'-0" | 11'-0" | 12'-0" |
| Steel 9 ga. | 2" (38.1) | 18.2 (27.1) | H-62009 | U | 1013 | 650 | 450 | 330 | 253 | 200 | 162 | 134 | 112 | 95 | 81 | 71 | 63 | 49 | 40 | 34 | 27 |
| | | | | D | .05 | .08 | .11 | .15 | .19 | .24 | .30 | .35 | .41 | .47 | .54 | .62 | .69 | .85 | 1.04 | 1.24 | 1.45 |
| | | | | C | 2274 | 1818 | 1516 | 1299 | 1136 | 1011 | 910 | 827 | 758 | 700 | 649 | 606 | 569 | 505 | 454 | 414 | 378 |
| | 2 1/2" (63.5) | 18.7 (27.8) | H-62509 | U | 1537 | 983 | 683 | 502 | 384 | 303 | 245 | 202 | 170 | 144 | 125 | 108 | 95 | 76 | 61 | 51 | 42 |
| | | | | D | .05 | .07 | .10 | .14 | .18 | .23 | .27 | .32 | .36 | .42 | .49 | .55 | .62 | .79 | .96 | 1.15 | 1.35 |
| | | | | C | 3446 | 2758 | 2298 | 1969 | 1724 | 1532 | 1378 | 1253 | 1148 | 1060 | 985 | 920 | 861 | 766 | 690 | 627 | 574 |
| | 3" (76.2) | 19.3 (28.7) | H-63009 | U | 1636 | 1047 | 727 | 534 | 408 | 322 | 261 | 215 | 181 | 154 | 134 | 115 | 100 | 80 | 64 | 54 | 46 |
| | | | | D | .04 | .06 | .08 | .11 | .15 | .18 | .22 | .26 | .30 | .34 | .39 | .44 | .48 | .58 | .68 | .80 | .95 |
| | | | | C | 3666 | 2934 | 2444 | 2096 | 1834 | 1629 | 1442 | 1333 | 1222 | 1129 | 1047 | 978 | 916 | 815 | 734 | 667 | 612 |
| | 4" (101.6) | 19.8 (29.4) | H-64009 | U | 2684 | 1717 | 1194 | 876 | 671 | 530 | 430 | 355 | 298 | 254 | 218 | 191 | 168 | 132 | 107 | 88 | 74 |
| | | | | D | .03 | .05 | .07 | .09 | .12 | .14 | .17 | .20 | .23 | .27 | .31 | .35 | .39 | .47 | .56 | .66 | .78 |
| | | | | C | 6014 | 4810 | 4008 | 3436 | 3006 | 2673 | 2406 | 2187 | 2004 | 1850 | 1718 | 1604 | 1505 | 1337 | 1143 | 1093 | 1002 |
| | | | | D | .03 | .04 | .06 | .07 | .09 | .11 | .14 | .16 | .19 | .22 | .25 | .28 | .31 | .38 | .45 | .53 | .63 |

Strut Concentrated - Loads/Deflections⁽²⁾

| Plank Width | Thickness | Concentrated C _s (lb./ft.) | |
|-------------|------------------|---------------------------------------|--------------|
| | | Serrated | Non-Serrated |
| 23 1/4" | 11 ga. Steel | 690 | 793 |
| | 10 ga. Steel | 788 | 906 |
| | 9 ga. Steel | 887 | 1019 |
| | Deflection (in.) | 0.11 | 0.10 |

C_s = Allowable Concentrated Load per ft. of length at mid-width (lb./ft.)

(2) See "General Load information", page 4, for explanation of design load deflection conditions.

Strut Uniform - Loads/Deflections⁽²⁾

| Plank Width | Thickness | Concentrated U (lb./ft.²) | |
|-------------|------------------|---------------------------|--------------|
| | | Serrated | Non-Serrated |
| 23 1/4" | 11 ga. Steel | 597 | 686 |
| | 10 ga. Steel | 682 | 784 |
| | 9 ga. Steel | 767 | 882 |
| | Deflection (in.) | 0.14 | 0.13 |

U = Allowable Uniform Load (lb./ft.²)

(2) See "General Load information", page 4, for explanation of design load deflection conditions.

Heavy Duty GRIP STRUT™ Plank - Safe Loading Tables

8-Diamond Plank — 36" Width — "H" Series

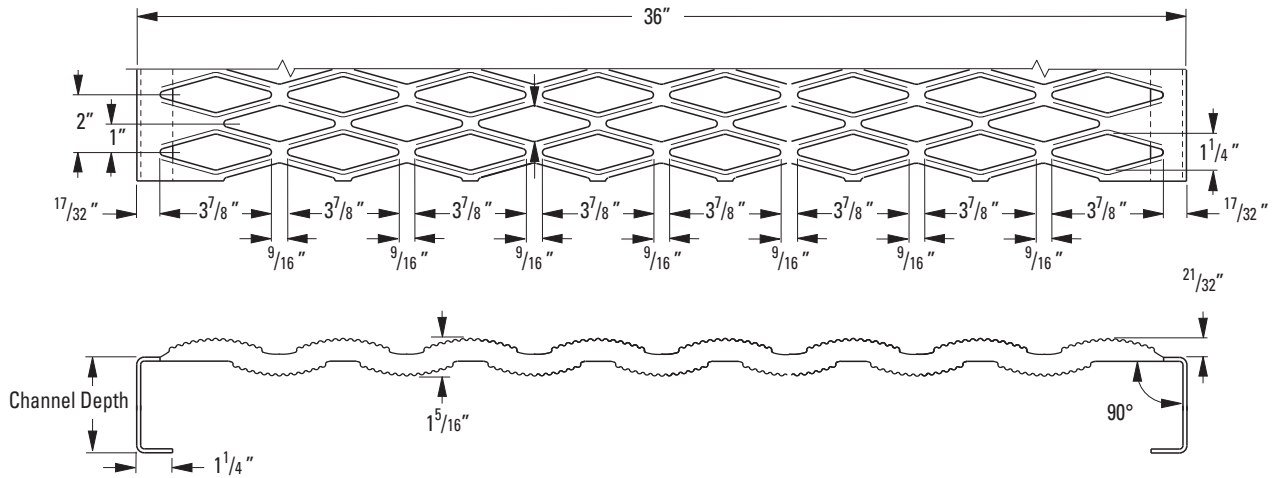

Plank Selection & Design Loads/Deflections

Allowable Loads and Deflections: U=Uniform Load (lb./ft.) C= Concentrated Load (lb.) D=Deflection (in.)

| Material Gauge | Channel Depth in. (mm) | Weight lb./lin. ft. (kg/m) | Catalog Number | Span | | | | | | | | | | | | | | | | | |
|-----------------|------------------------|----------------------------|----------------|-------|-------|-------|-------|-------|-------|-------|-------|-------|-------|-------|-------|-------|-------|--------|--------|--------|------|
| | | | | 2'-0" | 2'-6" | 3'-0" | 3'-6" | 4'-0" | 4'-6" | 5'-0" | 5'-6" | 6'-0" | 6'-6" | 7'-0" | 7'-6" | 8'-0" | 9'-0" | 10'-0" | 11'-0" | 12'-0" | |
| Steel 11 ga. | 2" (38.1) | 18.0 (26.8) | H-82011 | U | 620 | 397 | 275 | 203 | 155 | 122 | 99 | 82 | 69 | 59 | 50 | 44 | 39 | 31 | 25 | 21 | 17 |
| | | | | D | .05 | .08 | .11 | .15 | .19 | .24 | .30 | .35 | .41 | .47 | .54 | .62 | .69 | .85 | 1.04 | 1.24 | 1.45 |
| | | | | C | 1860 | 1488 | 1240 | 1063 | 930 | 827 | 744 | 677 | 620 | 572 | 531 | 496 | 465 | 413 | 372 | 338 | 310 |
| | | | | D | .04 | .06 | .09 | .12 | .15 | .19 | .24 | .28 | .33 | .38 | .44 | .49 | .55 | .68 | .81 | .98 | 1.16 |
| | 2 1/2" (63.5) | 18.4 (27.4) | H-82511 | U | 950 | 601 | 418 | 307 | 235 | 185 | 150 | 124 | 104 | 89 | 77 | 67 | 59 | 47 | 38 | 32 | 26 |
| | | | | D | .05 | .07 | .10 | .14 | .18 | .23 | .27 | .32 | .36 | .42 | .49 | .55 | .62 | .79 | .96 | 1.15 | 1.35 |
| | | | | C | 2820 | 2256 | 1880 | 1611 | 1410 | 1254 | 1128 | 1025 | 940 | 868 | 806 | 752 | 705 | 626 | 564 | 513 | 470 |
| | | | | D | .04 | .06 | .08 | .11 | .14 | .18 | .22 | .25 | .29 | .34 | .39 | .44 | .50 | .63 | .76 | .91 | 1.08 |
| | 3" (76.2) | 18.9 (28.1) | H-83011 | U | 1000 | 640 | 445 | 327 | 250 | 197 | 160 | 132 | 111 | 95 | 82 | 71 | 62 | 50 | 40 | 33 | 28 |
| | | | | D | .04 | .06 | .08 | .11 | .15 | .18 | .22 | .26 | .30 | .34 | .39 | .44 | .48 | .58 | .68 | .80 | .95 |
| | | | | C | 3000 | 2400 | 2000 | 1715 | 1500 | 1333 | 1180 | 1091 | 1000 | 923 | 857 | 800 | 750 | 667 | 600 | 545 | 500 |
| | | | | D | .03 | .05 | .07 | .09 | .12 | .15 | .17 | .21 | .24 | .28 | .31 | .35 | .39 | .47 | .55 | .64 | .76 |
| 4" (101.6) | 19.7 (29.3) | H-84011 | U | 1640 | 1049 | 729 | 536 | 410 | 324 | 263 | 217 | 182 | 156 | 134 | 117 | 103 | 81 | 66 | 54 | 45 | |
| | | | D | .03 | .05 | .07 | .09 | .12 | .14 | .17 | .20 | .23 | .27 | .31 | .35 | .39 | .47 | .56 | .66 | .78 | |
| | | | C | 4920 | 3936 | 3280 | 2812 | 2460 | 2187 | 1968 | 1789 | 1640 | 1514 | 1406 | 1312 | 1230 | 1094 | 935 | 895 | 820 | |
| | | | D | .03 | .04 | .06 | .07 | .09 | .11 | .14 | .16 | .19 | .22 | .25 | .28 | .31 | .38 | .45 | .53 | .63 | |
| Steel 10 ga. | 2" (50.8) | 19.9 (29.6) | H-82010 | U | 689 | 441 | 306 | 225 | 172 | 136 | 110 | 91 | 77 | 65 | 56 | 49 | 43 | 34 | 28 | 23 | 19 |
| | | | | D | .05 | .08 | .11 | .15 | .19 | .24 | .30 | .35 | .41 | .47 | .54 | .62 | .69 | .85 | 1.04 | 1.24 | 1.45 |
| | | | | C | 2067 | 1653 | 1378 | 1181 | 1033 | 919 | 827 | 752 | 689 | 636 | 590 | 551 | 517 | 459 | 413 | 376 | 344 |
| | | | | D | .04 | .06 | .09 | .12 | .15 | .19 | .24 | .28 | .33 | .38 | .44 | .49 | .55 | .68 | .81 | .98 | 1.16 |
| | 2 1/2" (63.5) | 20.4 (30.3) | H-82510 | U | 1044 | 668 | 464 | 341 | 261 | 206 | 167 | 138 | 116 | 99 | 85 | 74 | 65 | 52 | 42 | 35 | 29 |
| | | | | D | .05 | .07 | .10 | .14 | .18 | .23 | .27 | .32 | .36 | .42 | .49 | .55 | .62 | .79 | .96 | 1.15 | 1.35 |
| | | | | C | 3133 | 2507 | 2089 | 1790 | 1567 | 1393 | 1253 | 1139 | 1044 | 964 | 895 | 836 | 783 | 696 | 627 | 570 | 522 |
| | | | | D | .04 | .06 | .08 | .11 | .14 | .18 | .22 | .25 | .29 | .34 | .39 | .44 | .50 | .63 | .76 | .91 | 1.08 |
| | 3" (76.2) | 20.9 (31.1) | H-83010 | U | 1111 | 711 | 494 | 363 | 278 | 219 | 178 | 147 | 123 | 105 | 91 | 79 | 69 | 55 | 44 | 37 | 31 |
| | | | | D | .04 | .06 | .08 | .11 | .15 | .18 | .22 | .26 | .30 | .34 | .39 | .44 | .48 | .58 | .68 | .80 | .95 |
| | | | | C | 3333 | 2667 | 2222 | 1905 | 1667 | 1481 | 1311 | 1212 | 1111 | 1026 | 952 | 889 | 833 | 741 | 667 | 606 | 556 |
| | | | | D | .03 | .05 | .07 | .09 | .12 | .15 | .17 | .21 | .24 | .28 | .31 | .35 | .39 | .47 | .55 | .64 | .76 |
| 4" (101.6) | 21.8 (32.4) | H-84010 | U | 1822 | 1166 | 810 | 595 | 456 | 360 | 292 | 241 | 202 | 173 | 149 | 130 | 114 | 90 | 73 | 60 | 50 | |
| | | | D | .03 | .05 | .07 | .09 | .12 | .14 | .17 | .20 | .23 | .27 | .31 | .35 | .39 | .47 | .56 | .66 | .78 | |
| | | | C | 5467 | 4373 | 3644 | 3124 | 2733 | 2430 | 2187 | 1988 | 1822 | 1682 | 1562 | 1458 | 1367 | 1215 | 1039 | 994 | 911 | |
| | | | D | .03 | .04 | .06 | .07 | .09 | .11 | .14 | .16 | .19 | .22 | .25 | .28 | .31 | .38 | .45 | .53 | .63 | |

Heavy Duty GRIP STRUT™ Plank - Safe Loading Tables

8-Diamond Plank — 36" Width — "H" Series cont.

Plank Selection & Design Loads/Deflections

Allowable Loads and Deflections: U=Uniform Load (lb./ft.²) C= Concentrated Load (lb.) D=Deflection (in.)

| Material Gauge | Channel Depth in. (mm) | Weight lb./lin. ft (kg/m) | Catalog Number | | Span | | | | | | | | | | | | | | | | |
|----------------|------------------------|---------------------------|----------------|---|-------|-------|-------|-------|-------|-------|-------|-------|-------|-------|-------|-------|-------|-------|--------|--------|--------|
| | | | | | 2'-0" | 2'-6" | 3'-0" | 3'-6" | 4'-0" | 4'-6" | 5'-0" | 5'-6" | 6'-0" | 6'-6" | 7'-0" | 7'-6" | 8'-0" | 9'-0" | 10'-0" | 11'-0" | 12'-0" |
| Steel 9 ga. | 2" (38.1) | 22.1 (32.9) | H-82009 | U | 758 | 485 | 337 | 248 | 189 | 150 | 121 | 100 | 85 | 72 | 62 | 54 | 47 | 37 | 31 | 25 | 21 |
| | | | | D | .05 | .08 | .11 | .15 | .19 | .24 | .30 | .35 | .41 | .47 | .54 | .62 | .69 | .85 | 1.04 | 1.24 | 1.45 |
| | | | | C | 2274 | 1818 | 1516 | 1299 | 1136 | 1011 | 910 | 827 | 758 | 700 | 649 | 606 | 569 | 505 | 454 | 414 | 378 |
| | 2 1/2" (63.5) | 22.7 (33.8) | H-82509 | U | 1148 | 735 | 510 | 375 | 287 | 227 | 184 | 152 | 128 | 109 | 94 | 81 | 72 | 57 | 46 | 39 | 32 |
| | | | | D | .05 | .07 | .10 | .14 | .18 | .23 | .27 | .32 | .36 | .42 | .49 | .55 | .62 | .79 | .96 | 1.15 | 1.35 |
| | | | | C | 3446 | 2758 | 2298 | 1969 | 1724 | 1532 | 1378 | 1253 | 1148 | 1060 | 985 | 920 | 861 | 766 | 690 | 627 | 574 |
| | 3" (76.2) | 23.9 (35.5) | H-83009 | U | 1222 | 782 | 543 | 399 | 306 | 241 | 196 | 162 | 135 | 116 | 100 | 87 | 76 | 61 | 48 | 41 | 34 |
| | | | | D | .04 | .06 | .08 | .11 | .15 | .18 | .22 | .26 | .30 | .34 | .39 | .44 | .48 | .58 | .68 | .80 | .95 |
| | | | | C | 3666 | 2934 | 2444 | 2096 | 1834 | 1629 | 1442 | 1333 | 1222 | 1129 | 1047 | 978 | 916 | 815 | 734 | 667 | 612 |
| | 4" (101.6) | 24.2 (36.0) | H-84009 | U | 2004 | 1283 | 891 | 655 | 502 | 396 | 321 | 265 | 222 | 190 | 164 | 143 | 125 | 99 | 80 | 66 | 56 |
| | | | | D | .03 | .05 | .07 | .09 | .12 | .14 | .17 | .20 | .23 | .27 | .31 | .35 | .39 | .47 | .56 | .66 | .78 |
| | | | | C | 6014 | 4810 | 4008 | 3436 | 3006 | 2673 | 2406 | 2187 | 2004 | 1850 | 1718 | 1604 | 1504 | 1337 | 1143 | 1093 | 1002 |
| | | | | D | .03 | .04 | .06 | .07 | .09 | .11 | .14 | .16 | .19 | .22 | .25 | .28 | .31 | .38 | .45 | .53 | .63 |

Strut Concentrated - Loads/Deflections⁽²⁾

| Plank Width | Thickness | Concentrated C _s (lb./ft.) | |
|-------------|------------------|---------------------------------------|--------------|
| | | Serrated | Non-Serrated |
| 36" | 11 ga. Steel | 447 | 510 |
| | 10 ga. Steel | 515 | 587 |
| | 9 ga. Steel | 586 | 667 |
| | Deflection (in.) | 0.16 | 0.15 |

C_s = Allowable Concentrated Load per ft. of length at mid-width (lb./ft.)

(2) See "General Load information", page 4, for explanation of design load deflection conditions.

Strut Uniform - Loads/Deflections⁽²⁾

| Plank Width | Thickness | Concentrated U (lb./ft.²) | |
|-------------|------------------|---------------------------|--------------|
| | | Serrated | Non-Serrated |
| 36" | 11 ga. Steel | 298 | 340 |
| | 10 ga. Steel | 343 | 391 |
| | 9 ga. Steel | 391 | 444 |
| | Deflection (in.) | 0.20 | 0.19 |

U = Allowable Uniform Load (lb./ft.²)

(2) See "General Load information", page 4, for explanation of design load deflection conditions.

Heavy Duty GRIP STRUT™ Walkway - Safe Loading Tables

5-Diamond Planks — 24" Width — 5" Deep — "H" Series
6-Diamond Planks — 30" Width — 5" Deep — "H" Series
8-Diamond Planks — 36" Width — 5" Deep — "H" Series

Steel Walkway Selection Design Loads/Deflections

Allowable Loads and Deflections: U=Uniform Load (lb./ft.²) C= Concentrated Load (lb.) D=Deflection (in.)

| Steel Width Diamond | Material Gauge | Weight lb./lin. ft. (kg/m) | Catalog Number | | Span | | | | | | | | | | | | | | | | |
|---------------------|----------------|----------------------------|----------------|---|-------|-------|-------|-------|-------|-------|--------|--------|--------|--------|--------|--------|--------|--------|--------|--------|--------|
| | | | | | 4'-0" | 5'-0" | 6'-0" | 7'-0" | 8'-0" | 9'-0" | 10'-0" | 11'-0" | 12'-0" | 13'-0" | 14'-0" | 15'-0" | 16'-0" | 18'-0" | 20'-0" | 22'-0" | 24'-0" |
| 24" 5-Dia | 11 ga. | 15.4 (22.9) | H-55011-W | U | 750 | 480 | 334 | 245 | 187 | 148 | 120 | 99 | 83 | 71 | 62 | 54 | 47 | 37 | 30 | 25 | 21 |
| | | | | D | .34 | .35 | .38 | .34 | .34 | .34 | .35 | .42 | .50 | .59 | .69 | .79 | .91 | 1.13 | 1.43 | 1.70 | 2.03 |
| | | | | C | 3000 | 2400 | 2000 | 1714 | 1500 | 1334 | 1200 | 1091 | 1000 | 922 | 857 | 800 | 750 | 666 | 600 | 546 | 500 |
| | | | | D | .27 | .28 | .31 | .28 | .28 | .27 | .28 | .34 | .41 | .48 | .56 | .63 | .72 | .91 | 1.13 | 1.36 | 1.62 |
| | 10 ga. | 17.5 (26.0) | H-55010-W | U | 937 | 600 | 417 | 306 | 234 | 185 | 150 | 124 | 104 | 89 | 77 | 67 | 59 | 46 | 38 | 31 | 26 |
| | | | | D | .38 | .39 | .42 | .38 | .38 | .38 | .39 | .47 | .56 | .66 | .77 | .88 | 1.01 | 1.26 | 1.59 | 1.89 | 2.25 |
| | | | | C | 3750 | 3000 | 2500 | 2143 | 1875 | 1667 | 1500 | 1364 | 1250 | 1153 | 1071 | 1000 | 938 | 833 | 750 | 682 | 625 |
| | | | | D | .30 | .31 | .34 | .31 | .30 | .30 | .31 | .36 | .45 | .53 | .61 | .70 | .80 | 1.01 | 1.25 | 1.51 | 1.80 |
| | 9 ga. | 19.6 (29.1) | H-55009-W | U | 1031 | 660 | 459 | 337 | 257 | 204 | 165 | 136 | 114 | 98 | 85 | 74 | 65 | 51 | 42 | 34 | 29 |
| | | | | D | .38 | .39 | .42 | .38 | .38 | .38 | .39 | .47 | .56 | .66 | .77 | .88 | 1.01 | 1.26 | 1.59 | 1.89 | 2.25 |
| | | | | C | 4125 | 3300 | 2750 | 2357 | 2063 | 1834 | 1650 | 1500 | 1375 | 1268 | 1178 | 1100 | 1032 | 916 | 825 | 750 | 688 |
| | | | | D | .30 | .31 | .34 | .31 | .30 | .30 | .31 | .36 | .45 | .53 | .61 | .70 | .80 | 1.01 | 1.25 | 1.51 | 1.80 |
| 30" 6-Dia | 11 ga. | 17.7 (26.3) | H-65011-W | U | 732 | 468 | 325 | 239 | 183 | 145 | 116 | 96 | 81 | 69 | 60 | 52 | 45 | 36 | 28 | 24 | 20 |
| | | | | D | .33 | .39 | .36 | .36 | .41 | .38 | .37 | .37 | .44 | .51 | .59 | .68 | .77 | .98 | 1.20 | 1.46 | 1.73 |
| | | | | C | 3667 | 2932 | 2444 | 2095 | 1832 | 1629 | 1467 | 1333 | 1222 | 1128 | 1047 | 977 | 916 | 815 | 732 | 667 | 610 |
| | | | | D | .27 | .31 | .29 | .29 | .33 | .31 | .30 | .30 | .35 | .41 | .48 | .55 | .62 | .78 | .97 | 1.17 | 1.40 |
| | 10 ga. | 19.9 (29.6) | H-65010-W | U | 916 | 586 | 407 | 299 | 229 | 182 | 146 | 121 | 102 | 87 | 75 | 65 | 57 | 45 | 36 | 30 | 25 |
| | | | | D | .37 | .43 | .40 | .40 | .46 | .42 | .41 | .41 | .49 | .57 | .66 | .75 | .86 | 1.09 | 1.33 | 1.62 | 1.92 |
| | | | | C | 4584 | 3666 | 3056 | 2619 | 2291 | 2037 | 1834 | 1667 | 1528 | 1410 | 1309 | 1222 | 1146 | 1019 | 916 | 834 | 763 |
| | | | | D | .30 | .34 | .32 | .32 | .37 | .34 | .33 | .33 | .39 | .45 | .53 | .61 | .69 | .87 | 1.08 | 1.30 | 1.55 |
| | 9 ga. | 22.1 (32.9) | H-65009-W | U | 1007 | 644 | 447 | 328 | 251 | 200 | 160 | 133 | 112 | 95 | 82 | 71 | 62 | 49 | 39 | 33 | 27 |
| | | | | D | .37 | .43 | .40 | .40 | .46 | .42 | .41 | .41 | .49 | .57 | .66 | .75 | .86 | 1.09 | 1.33 | 1.62 | 1.92 |
| | | | | C | 5042 | 4032 | 3361 | 2880 | 2530 | 2240 | 2017 | 1833 | 1680 | 1551 | 1439 | 1344 | 1260 | 1120 | 1007 | 917 | 839 |
| | | | | D | .30 | .34 | .32 | .32 | .37 | .34 | .33 | .33 | .39 | .45 | .53 | .61 | .69 | .87 | 1.08 | 1.30 | 1.55 |
| 36" 8-Dia | 11 ga. | 20.2 (30.0) | H-85011-W | U | 444 | 284 | 197 | 144 | 111 | 88 | 71 | 58 | 49 | 42 | 36 | 31 | 28 | 21 | 17 | 14 | 12 |
| | | | | D | .35 | .35 | .30 | .29 | .30 | .32 | .35 | .38 | .46 | .54 | .62 | .71 | .82 | 1.04 | 1.26 | 1.50 | 1.78 |
| | | | | C | 2664 | 2133 | 1777 | 1524 | 1333 | 1184 | 1066 | 969 | 888 | 820 | 761 | 711 | 666 | 592 | 533 | 484 | 444 |
| | | | | D | .28 | .28 | .23 | .23 | .23 | .26 | .28 | .31 | .37 | .43 | .50 | .58 | .65 | .83 | 1.02 | 1.23 | 1.47 |
| | 10 ga. | 22.7 (33.8) | H-85010-W | U | 556 | 356 | 247 | 181 | 139 | 110 | 89 | 73 | 62 | 53 | 45 | 39 | 35 | 27 | 22 | 18 | 15 |
| | | | | D | .39 | .39 | .33 | .32 | .33 | .36 | .39 | .42 | .51 | .60 | .69 | .79 | .91 | 1.15 | 1.40 | 1.67 | 1.98 |
| | | | | C | 3330 | 2667 | 2222 | 1905 | 1667 | 1481 | 1333 | 1212 | 1111 | 1026 | 952 | 889 | 833 | 741 | 667 | 606 | 556 |
| | | | | D | .31 | .31 | .26 | .26 | .26 | .29 | .31 | .34 | .41 | .46 | .55 | .64 | .72 | .92 | 1.13 | 1.37 | 1.63 |
| | 9 ga. | 25.3 (37.6) | H-85009-W | U | 611 | 391 | 271 | 199 | 152 | 121 | 97 | 80 | 68 | 58 | 49 | 42 | 38 | 29 | 24 | 19 | 16 |
| | | | | D | .39 | .39 | .33 | .32 | .33 | .36 | .39 | .42 | .51 | .60 | .69 | .79 | .91 | 1.15 | 1.40 | 1.67 | 1.98 |
| | | | | C | 3663 | 2933 | 2444 | 2095 | 1833 | 1629 | 1466 | 1333 | 1222 | 1128 | 1047 | 977 | 916 | 815 | 733 | 666 | 611 |
| | | | | D | .31 | .31 | .26 | .26 | .26 | .29 | .31 | .34 | .41 | .46 | .55 | .64 | .72 | .92 | 1.13 | 1.37 | 1.63 |

Heavy Duty GRIP STRUT™ Walkway - Safe Loading Tables

5-Diamond Planks — 24" Width — 5" Deep — "H" Series cont.
6-Diamond Planks — 30" Width — 5" Deep — "H" Series cont.
8-Diamond Planks — 36" Width — 5" Deep — "H" Series cont.

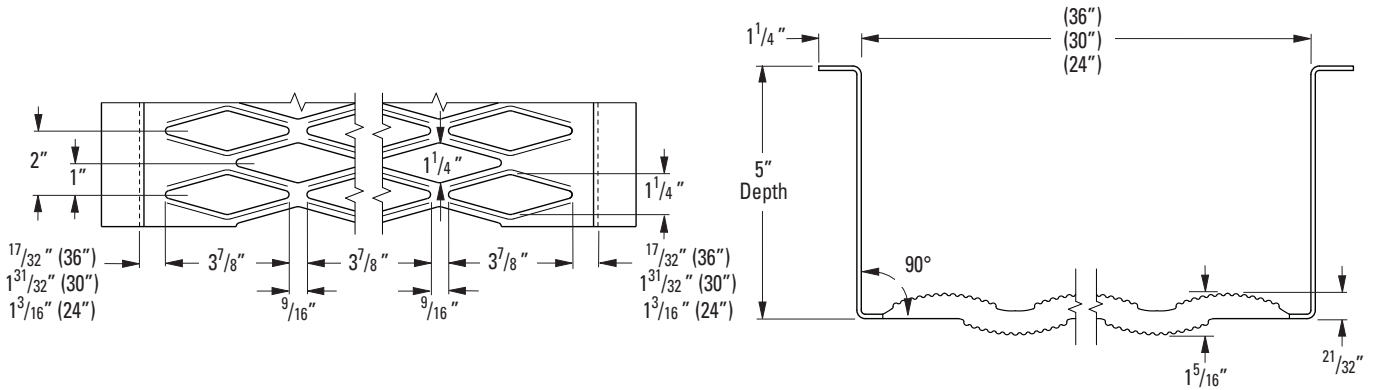

Strut Concentrated - Loads/Deflections⁽²⁾

| Walkway Width | Thickness - Material | Concentrated C _s (lb./ft.) | |
|---------------|----------------------|---------------------------------------|--------------|
| | | Serrated | Non-Serrated |
| 24" | 11 ga. - Steel | 798 | 917 |
| | 10 ga. - Steel | 912 | 1048 |
| | 9 ga. - Steel | 1026 | 1179 |
| | Deflection (in.) | 0.08 | 0.07 |
| 30" | 11 ga. - Steel | 537 | 612 |
| | 10 ga. - Steel | 618 | 704 |
| | 9 ga. - Steel | 703 | 800 |
| | Deflection (in.) | 0.11 | 0.10 |
| 36" | 11 ga. - Steel | 447 | 510 |
| | 10 ga. - Steel | 515 | 587 |
| | 9 ga. - Steel | 586 | 667 |
| | Deflection (in.) | 0.16 | 0.15 |

C_s = Allowable Concentrated Load per ft. of length at mid-width (lb./ft.)

(2) See "General Load information", page 4, for explanation of design load deflection conditions.

Strut Uniform - Loads/Deflections⁽²⁾

| Walkway Width | Thickness - Material | Uniform U (lb./ft. ²) | |
|---------------|----------------------|-----------------------------------|--------------|
| | | Serrated | Non-Serrated |
| 24" | 11 ga. - Steel | 798 | 917 |
| | 10 ga. - Steel | 912 | 1048 |
| | 9 ga. - Steel | 1026 | 1179 |
| | Deflection (in.) | 0.11 | 0.10 |
| 30" | 11 ga. - Steel | 429 | 490 |
| | 10 ga. - Steel | 494 | 563 |
| | 9 ga. - Steel | 563 | 640 |
| | Deflection (in.) | 0.14 | 0.13 |
| 36" | 11 ga. - Steel | 298 | 340 |
| | 10 ga. - Steel | 343 | 391 |
| | 9 ga. - Steel | 391 | 444 |
| | Deflection (in.) | 0.20 | 0.19 |

U = Allowable Uniform Load (lb./ft.²)

(2) See "General Load information", page 4, for explanation of design load deflection conditions.

Heavy Duty GRIP STRUT™ Walkway - Application



Heavy Duty GRIP STRUT™ Grating Accessories

Heavy Duty GRIP STRUT Hold-Down Clip
catalog number **H-BC-10** (G-90 Mill Galvanized);
use with $\frac{3}{8}$ " square-shank carriage bolts, nuts
and washers obtained locally.
Also available in stainless steel.

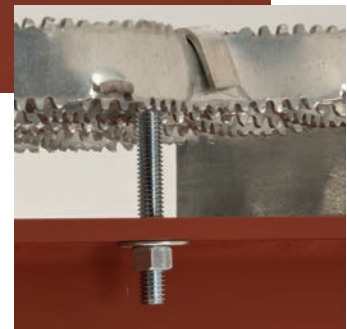
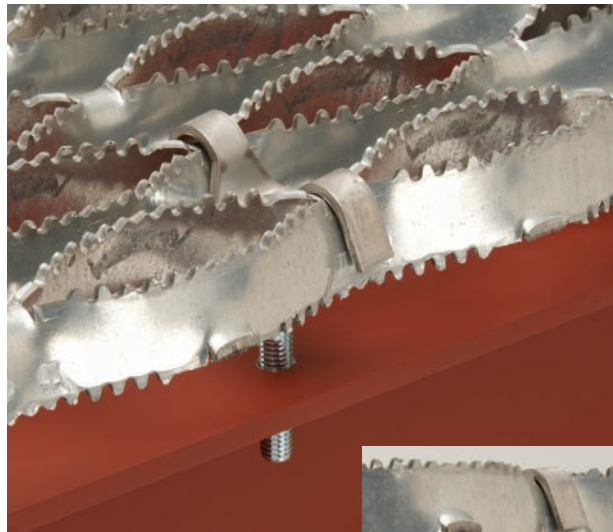

Walkway Splice Plate, catalog number **P-H-SP-U**,
formed from 9 gauge mill-galvanized steel, prepunched
and supplied with $\frac{1}{2}$ " hex bolts, nuts and washers.
Torque to 40 ft.-lbs.

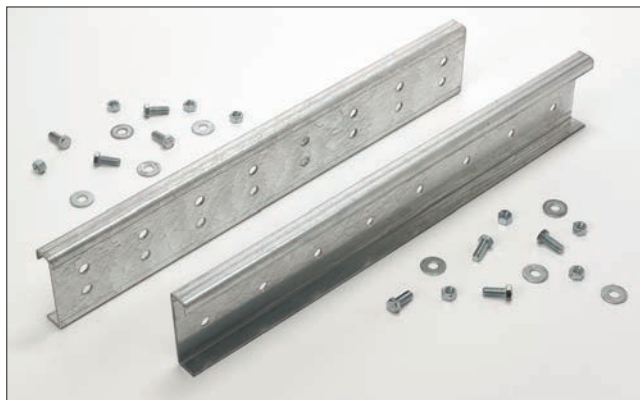

Accessories

Handrail Brackets are available for application on Heavy Duty GRIP STRUT™ steel walkways. This is a valuable accessory for those projects where utilization of Heavy Duty GRIP STRUT steel walkway is desired for its superior long spanability. Handrailing with handrail post on maximum eight foot center is required per OSHA. The Handrail Brackets eliminate unnecessary and costly substructure to support handrail post.

The assembly of Heavy Duty GRIP STRUT steel walkway with the handrail brackets has been tested as a proper moment connection for handrail post to standards as outlined in "OSHA" 1910.23.

Handrail Brackets come in two styles; Universal Type and Clip Angle Type, and can be ordered by the following catalog system;



Typical catalog number

HRB-Hand Rail Bracket
5, 6, or 8 Diamond
HRB-A-5
A (Clip Angle Type)
or
UNIV_HRB_P (Universal Type)

Clip Angle/Handrail Bracket (HRB-A-_)

is designed for use with all types of Handrail Post; Pipe, Angle, Tube etc. Handrail Post may be mounted to Handrail Bracket with two 1/2" bolts and nuts (not included) to holes conveniently located, or by welding.

Handrail brackets are sold in plain non-finished steel but may be ordered in a hot dipped galvanized after fabrication finish. All hardware for mounting Handrail Bracket to Heavy Duty steel walkway is included.

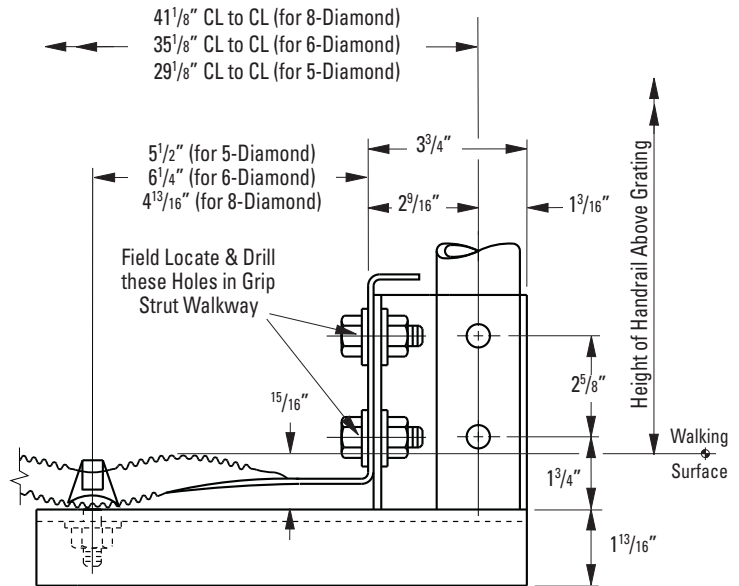

Universal Handrail Bracket (UNIV_HRB_P)

is designed for use with pipe style handrail post (maximum 2" O.D.) which allows for simple installation of handrail post. Secure post by tightening two allen head set screws.

Handrail bracket is sold in plain non-finish steel but may be ordered in a hot dipped galvanized after fabrication finish. All hardware for mounting handrail bracket to Heavy Duty Steel walkway is included.

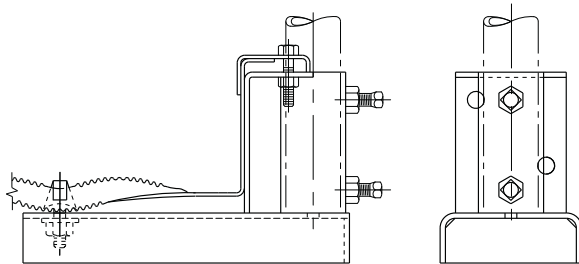

Universal Handrail Bracket permits attachment without drilling

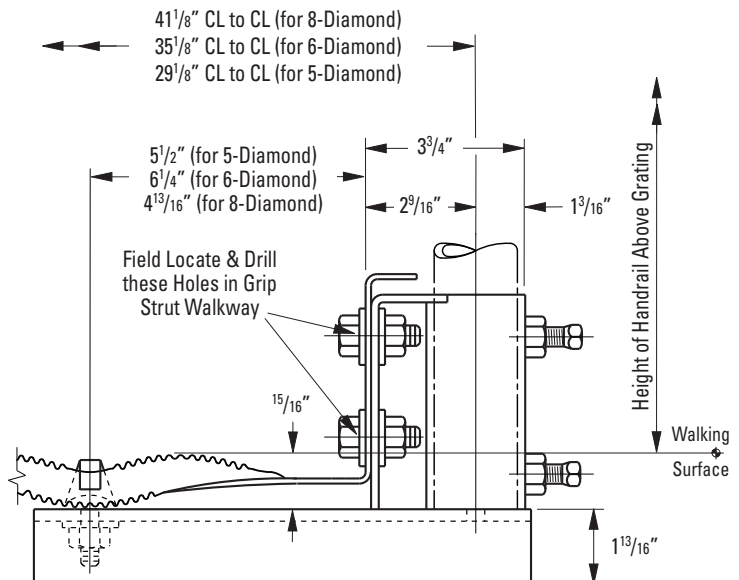

A Step Ahead With Safety, Two Ways

No-where is sole-gripping design more critical than on stairs, where feet are more prone to slip, often with severe consequences. Heavy Duty GRIP STRUT™ stair treads provide the sole-gripping qualities of GRIP STRUT safety grating for extra safety in two ways: multi-directional scraping action of tiny-toothed surfaces keeps shoes clean; open design rids surface of debris. The open area also makes threads easy to see, and edges read well from above.

Heavy Duty GRIP STRUT stair treads are available in standard nosing style only, 10-gauge steel: one depth (2"), two widths (9¹/₄", 13³/₄"), and four standard spans (24", 30", 36", 48"), with others available upon request. They are ideal for new construction, or easily attached to stringers for rehabilitation of existing stairs.

Heavy-Duty GRIP STRUT — 2-Diamond Stair Tread Construction

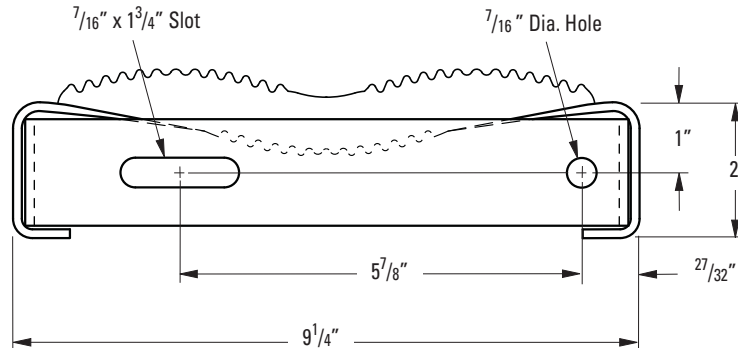

Stair Tread Selection & Design Loads ⁽¹⁾

Allowable Loads and Deflections: U=Uniform Load (lb./ft.²) C= Concentrated Load (lb.) D=Deflection (in.)

| Material | Thickness | Depth in. | Weight lb./lin. ft. (kg/m) | Catalog Number | Load Type | Clear Span | | | |
|----------|-----------|-----------|----------------------------|----------------|-----------|------------|-------|-------|----------------------|
| | | | | | | 2'-0" | 2'-6" | 3'-0" | 4'-0" ⁽²⁾ |
| Steel | 10 ga. | 2" | 7.4 (11.0) | HT22010 | U | 2412 | 1544 | 1026 | 629 |
| | | | | | C | 1860 | 1487 | 1240 | 929 |

(1) See "General Load information", page 4, for explanation of design load deflection conditions.

(2) For stair treads, intermediate stringer is recommended for spans over 4 feet.

Fabricating Services

We can quote large jobs on a lump-sum basis, including detailing and fabricating of special material, to your requirements. Submit plans and specifications through your GRIP STRUT™ safety grating distributor.

After your order is received, a bill of materials and shop drawings will be prepared for your approval before fabrication is begun. A few of the fabricating services available include:

- Special cutting
- Marking according to layout
- Banding
- Toe plates



Specifications

Notes to architect

1. These specifications are presented as a general guide to the architect or structural engineer in preparing project specifications. Allowable loads, spans, and other limiting conditions presented in this catalog are product data for use in design and construction. These products must not be used without prior structural design by a qualified engineer or architect.
2. GRIP STRUT™ Safety Gratings are intended for general purpose use in plants and process facilities by industry, commerce, and public utilities.
GRIP STRUT Safety Grating Stair Treads are intended for utility stairs and fire escapes in commercial, industrial buildings where local code permits. They are not intended for staircases and other areas used regularly by the general public where flat closed surfaces are desired.
3. All supports should 1½" minimum bearing surface free of burrs, bridging, welds and other irregularities. (Note: When using Butterfly Anchor Clips "H-BC-10" it is advisable to provide a minimum of 3" for bearing per support per grating).
4. Random-, diagonal- or circular-cut exposed edges should be reinforced with a bar of grating thickness (minimum 1/8") and width equal to overall grating depth, welded at contact points of the designer's discretion.
5. Bolted connections, except stair or ladder tread attachment to stringers, may be replaced by welded connections of equal or greater strength.

Part 1: General

1.1 Scope

The contractor shall furnish and install GRIP STRUT Grating and Stair Treads, as specified, in all areas where shown on the drawings.

1.2 Qualifications

All GRIP STRUT Grating, Stair Tread and accessories, unless otherwise indicated, shall be manufactured by Eaton's B-Line Business, and shall be installed in accordance with its current recommendations.

1.3 Submittals

The contractor shall furnish shop drawings of grating layout, framing and supports, unit dimensions and sections, fastener and weld types and locations.

1.4 storage and Handling

All materials shall be stored and handled to avoid damage. Damaged or deteriorated materials shall be removed from the premises.

Part 2: Products

2.1 Gratings

- a. **Type:** Heavy Duty GRIP STRUT Safety Grating (Plank) (Walkway).
- b. **Metal:** (carbon steel).
- c. **Finish:** mill-galvanized before fabrication, ASTM A653 G-90 plain, unpainted, and oiled (HRP&O); mill finish (aluminum).
- d. **Metal gauge:** 11-ga., 10-ga., 9-ga. (ASG steel); .125" (aluminum).
- e. **Section width:** 9¼", 13¾", 23¼", 27¾", 36" (plank); 24", 30", 36" (walkway).
- f. **Side channel height:** 2", 2½", 3", 4" (plank); 5" (walkway), also Canadian OH & S compliant.
- g. **Standard lengths:** 10'-0", 12'-0", 24'-0" (walkway); 10'-0", 12'-0", special order (plank).
- h. **Opening diamond:** "H" Series, 3⅞" x 1¼" wide (grating surface-projected dimensions).
- i. **Reticulated pattern:** 1⅝" high, minimum of 500 teeth per square foot.
- j. **Slip resistance:** Complies with Federal Specification RR-G-1602D standards.
- k. **Surface texture:** Standard serrated, non-serrated, and reduced opening.

2.2 Stair Treads

- a. **Type:** Heavy Duty GRIP STRUT™ Stair Tread, Standard Nosing.
- b. **Metal:** carbon steel - ASTM A653 G-90.
- c. **Finish:** mill-galvanized before fabrication, ASTM A525 plain, unpainted, and oiled (HRP&O); mill finish (aluminum).
- d. **Metal thickness:** 10-ga. (ASG, steel); .125" (aluminum).
- e. **Section width:** 9¹/₂".
- f. **Side channel height:** 2".
- g. **Standard lengths:** (2", 2¹/₂", 36", 4" (nominal and actual), ±¹/₈"
- h. **Opening diamond:** "H" Series, 3⁷/₈" x 1¹/₄" wide (grating surface-projected dimensions).
- i. **Open area:** 52%.
- j. **Reticulated pattern:** 1⁵/₁₆" high, minimum of 500 teeth per square foot.
- k. **Slip resistance:** Complies with Federal Specification RR-G-1602D standards.

2.3 Accessories

Heavy Duty GRIP STRUT Hold-Down Clip, stainless steel, Catalog Number H-BC-10. (Use with ³/₈" square-shank carriage bolts, nuts, and washers obtained locally).

Handrail Bracket - hardware to attach bracket to walkway is supplied. Optional hot dipped galvanized after fabrication is available per request.

Heavy Duty GRIP STRUT Splice Plate (P-H-SP-U), 30", 9 gauge mill-galvanized steel splice plate with bolts, hex nuts, and washers.

Part 3: Execution

3.1 Bearing surfaces

Prior to grating installation, inspect supports for correct size, layout and alignment, and verify that bearing surfaces are smooth and free of debris. Report in writing to the engineer or owner's agent and defects so they can be corrected before grating is installed.

3.2 Grating installation

Install grating in accordance with manufacturer's recommendations and shop drawings. Position grating sections flat and square with ends bearing min. 1¹/₂" on supporting structure; for sections over 12'-0" long, and when Heavy Duty GRIP STRUT Hold-Down Clips are used, 3" minimum bearing surface is required. Bearing surface must be smooth, level, free of burrs, bridging, welds and other irregularities. Space grating sections a minimum ¹/₄" from vertical steel sections, and ¹/₂" from concrete walls. Allow maximum clearance between sections at joints of ¹/₄" at side channels, ³/₈" at ends.

Band random-cut ends and diagonal or circular cut exposed edges with a bar of grating thickness (min. ¹/₈") and width equal to overall depth, welded at contact points of the designer's discretion.

3.3 Grating attachment

Attach grating to supports without warp or deflection as follows:

- a. **Single plank application:** Secure plank ends to supporting members at every point of contact. At each end, use Heavy Duty GRIP STRUT Hold-Down Clips with ³/₈" square shank carriage bolts and nuts, or secure each side channel to support by ¹/₈" x 1" long fillet welds.
- b. **Multiple plank application:** Secure perimeter plank to supporting members with ¹/₈" x 1" long fillet welds at every point of contact, intermediate grating sections with at least one attachment each end on alternate sides. When span exceeds 6'-0", attach side channels of adjacent planks together at mid-point of span for added rigidity. To joint adjacent planks together, weld them at 24" O.C. staggered top and bottom.

3.4 Stair Tread Installation

Fasten GRIP STRUT Stair Treads shown on the drawings, or as herein specified, to stair stringers with ³/₈" x 1" machine bolts and nuts.

- a. **For stair treads,** intermediate stringer is recommended for spans over 4 feet.

How To Order

Heavy Duty GRIP STRUT™ safety grating planks, walkways and stair treads are stocked at local GRIP STRUT safety grating distributors in all major market areas. For the finest in Safety Grating and Stair Treads, contact us or look for your local GRIP STRUT distributor on the internet at www.bline.com. You will get skilled consulting service on your specific requirements.

All standard products are coded with a catalog number which should be used in ordering. For identification and ordering information on special products, consult your GRIP STRUT safety grating distributor or contact us.

Catalog number code

Plank and walkway catalog numbers

denote product configuration as follows:

Steel —

Standard material is mill-galvanized per ASTM A653. For plain, unpainted steel, “B” follows the five-digit catalog number coded below.

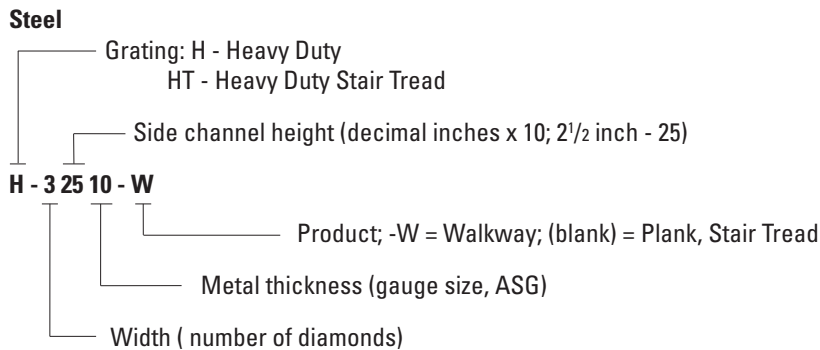

Examples: Catalog Number H-82010 denotes a mill-galvanized, 10 gauge steel plank of 8-diamond (36") width and 2" high side channels;

Catalog Number H-65009-WB denotes a plain, unpainted, 9 gauge steel walkway of 6-diamond (30") width and 5" high side channels.

Stair Tread catalog numbers —

Use the above coding preceded by “HT” to denote stair tread.

Example: Catalog Number HT-22010-B denotes a stair tread of plain, unpainted, 10 gauge steel, 2-diamond (9 1/4") width and 2" high deep side channels.

U.S. Customer Service Center is staffed Monday through Friday
from 7 a.m. to 5:00 p.m. Central Standard Time.
For more information visit, www.cooperblineline.com/grating.

Eaton's B-Line Business
509 West Monroe Street
Highland, IL 62249
United States
Phone: (800) 582-3643
www.cooperblineline.com/contactus

Eaton
1000 Eaton Boulevard
Cleveland, OH 44122
United States
Eaton.com

Eaton's B-Line Business
509 West Monroe Street
Highland, IL 62249
Phone: 800-851-7415
Fax: 618-654-1917
www.cooperblineline.com

© 2014 Eaton
All Rights Reserved
Printed in USA
Publication No. GSHDGS-13R
August 2014

Eaton is a registered trademark

All other trademarks are property
of their respective owners.