



**Stair Components & Systems**  
A Division of Eberl Iron Works, Inc.

# ORDER FORMS MANUAL



*Serving the Needs of Our Customers Since 1923*



## EBERL IRON WORKS, INC.

Founded in 1923, by brothers George and Frank Eberl, EIW began as a small welding shop, fabricating wrought iron railings, exterior fire escapes and miscellaneous iron.

We've come a long way since those days. We now specialize in custom shearing and forming of steel sheets and plates. Working with customer specifications, we are dedicated to providing the highest quality formed shapes out of: hot rolled, cold rolled, galvanized and stainless steels, as well as aluminum and copper.

We have a selection of custom products for Original Equipment Manufactures, and for the Structural and Miscellaneous Steel Industries, including: stairpans, stair treads, bent plate, pour stop, u-edging hems, masonry clips, and industrial pipe guards.

# HOW TO USE THIS MANUAL

This manual was designed to help customers obtain quotes for stairpans, stair treads and other stair system components. Simply locate and download or print the form for the desired item, fill the form out and then return it.

Be sure to fill in all dimensions, including: quantity, material thickness, and length. Also let us know, in the "Mark" field, how you would like us to label your stair components. Marking helps make the receiving and installation processes much more efficient. Note special requirements for notching, punching, and painting.

Forms are fillable and may be completed on your device and emailed, or printed and filled out by hand, then faxed or scanned and emailed back to us.

Quotes are typically turned around in 1 business day or less.

**SAMPLE**

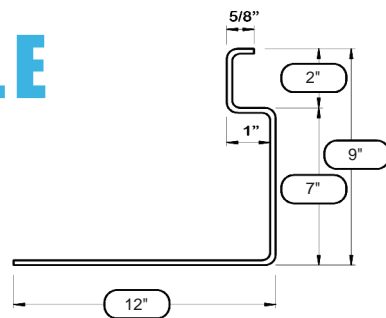

**COMBINATION TREAD & RISER**

QTY	Gauge	Length	Mark
12	12 ga	42"	1P2

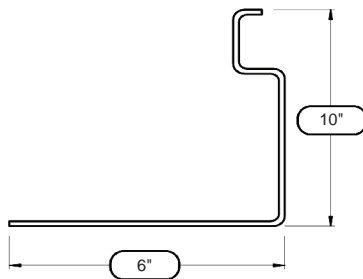

**LANDING RISER**

QTY	Gauge	Length	Mark
1	12 ga	42"	1P3

ORDER FORMS MANUAL

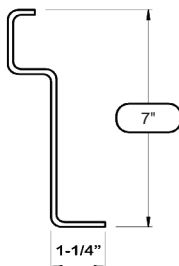

**STARTER RISER**

QTY	Gauge	Length	Mark
1	12 ga	42"	1P1

Customer	Eberl Iron Works	Type	<b>1A</b>
Order #	123456	Scale	
Job Name	OFM-Sample	Date	

# BENT PLATE

METAL ANGLE

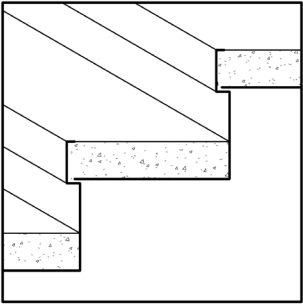

METAL CHANNEL

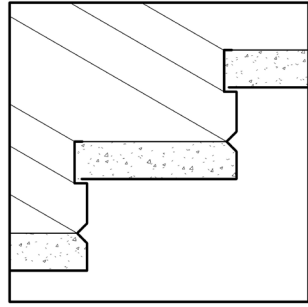

C-CHANNEL

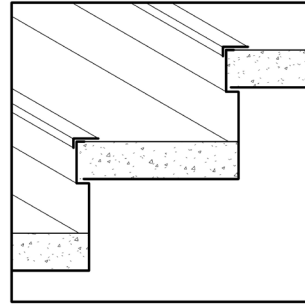

TAPERED CHANNEL

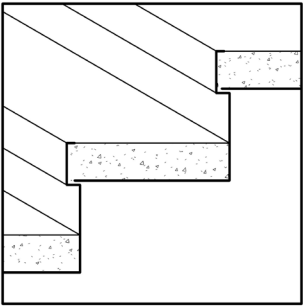

HAT CHANNEL

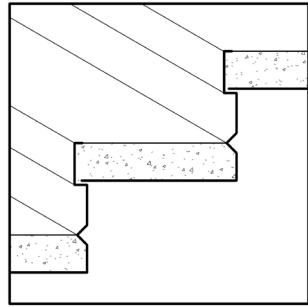

HAT SECTION

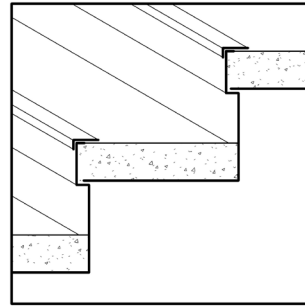

DOWNSPOUT COVERS

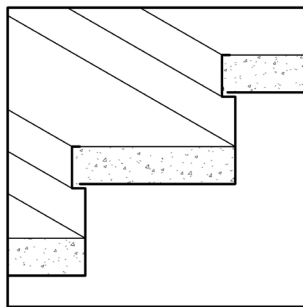

METAL CHANNEL

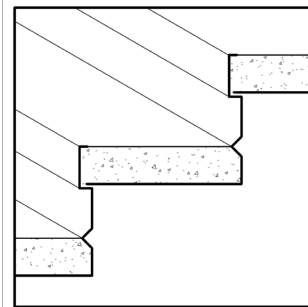

C-CHANNEL

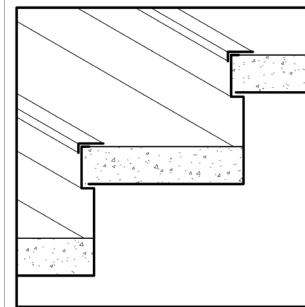

# LOADING DOCK PRODUCTS

CANOPY HOODS

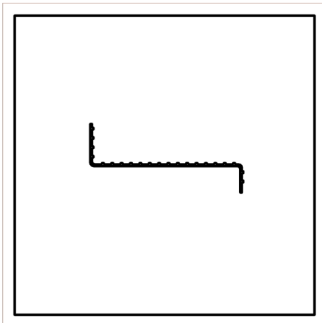

DOCK PLATES

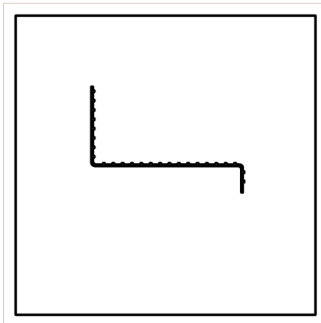

TYPE 26  
STAIR TREAD

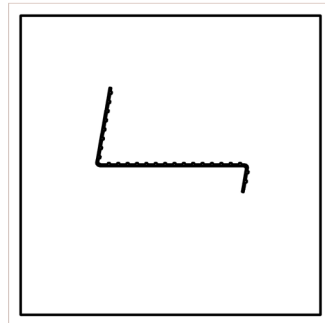

# STAIR COMPONENTS

LANDING PANS

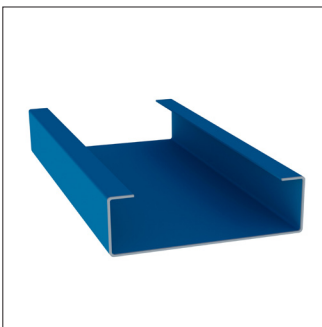

NOSINGS

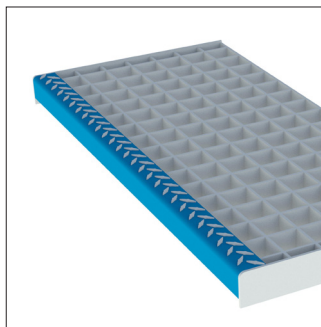

CARRIER ANGLES

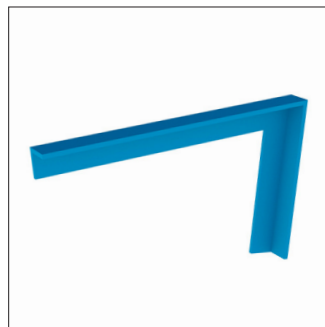

# STAIRPAN TYPE 1A

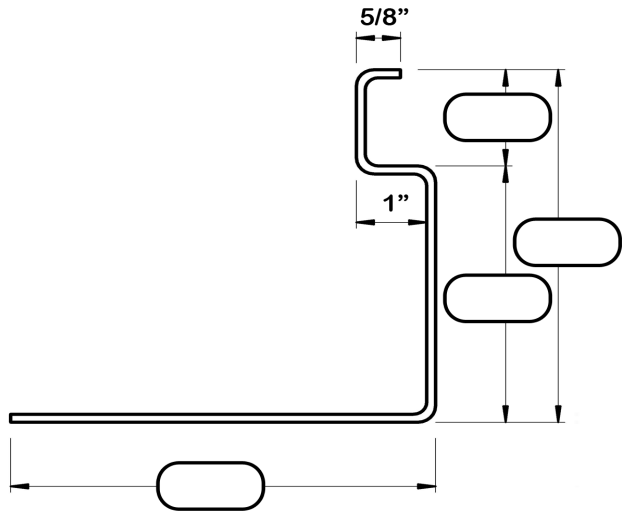

## COMBINATION TREAD & RISER

QTY	Gauge	Length	Mark

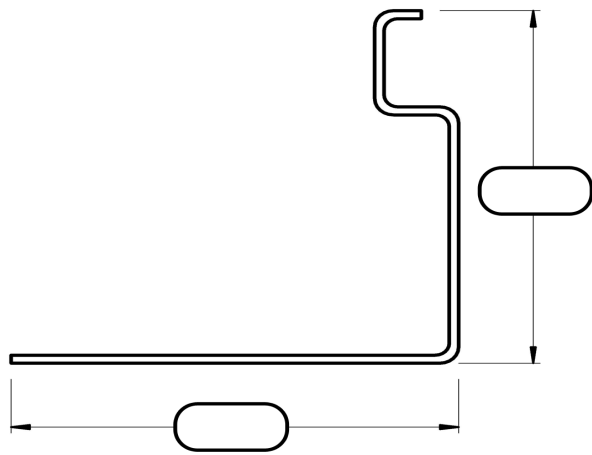

## LANDING RISER

QTY	Gauge	Length	Mark

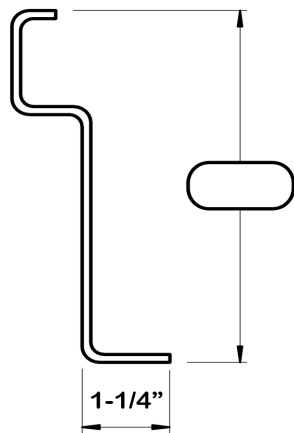

## STARTER RISER

QTY	Gauge	Length	Mark



Stair Components & Systems

1 (800) 285-3056

Customer	Type	<b>1A</b>
Order #	Scale	
Job Name	Date	

email: fab@eberliron.com

stairpans.com

# STAIRPAN TYPE 1B

## COMBINATION TREAD & RISER

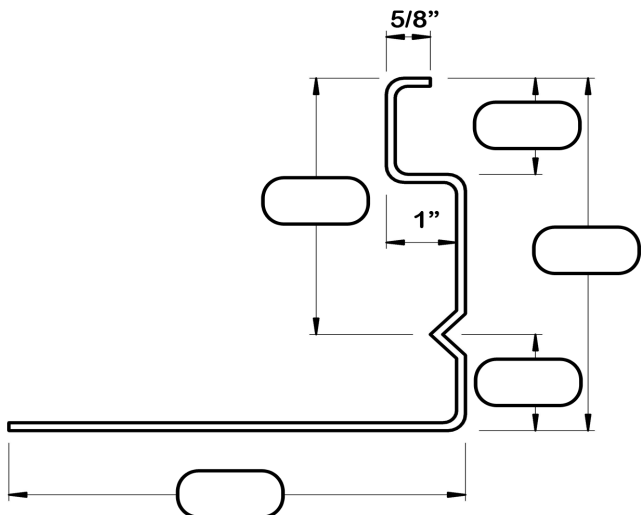

QTY	Gauge	Length	Mark

## LANDING RISER

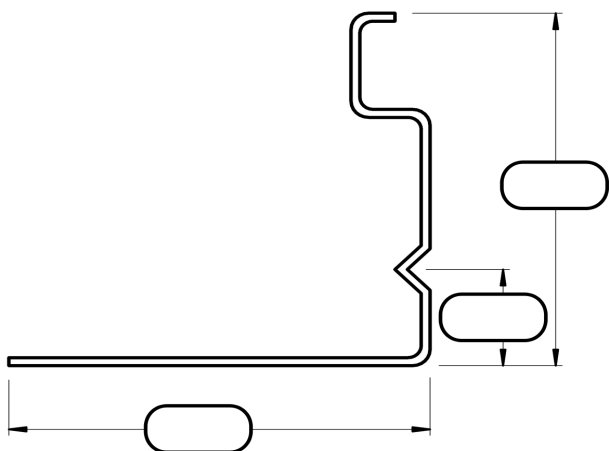

QTY	Gauge	Length	Mark

## STARTER RISER

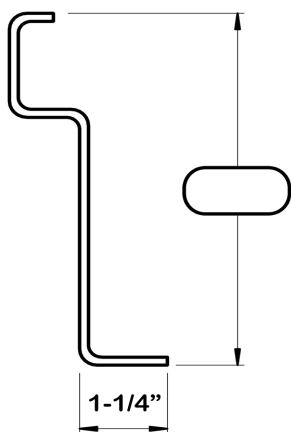

QTY	Gauge	Length	Mark

ORDER FORMS MANUAL



Stair Components & Systems

1 (800) 285-3056

Customer	Type	<b>1B</b>
Order #	Scale	
Job Name	Date	

email: fab@eberliron.com

stairpans.com

# STAIRPAN TYPE 1C

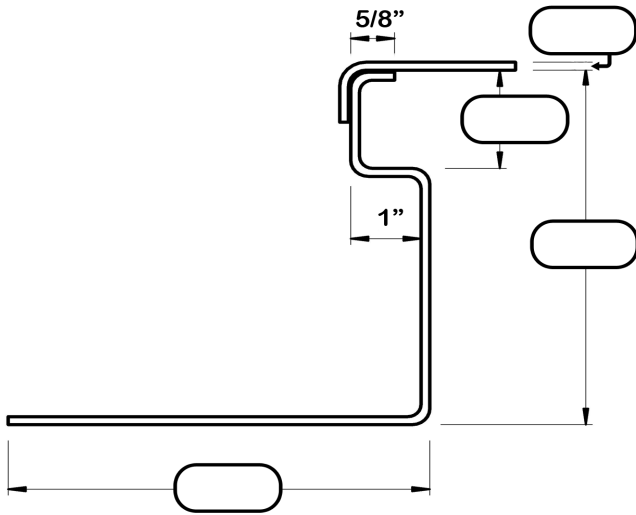

## COMBINATION TREAD & RISER

QTY	Gauge	Length	Mark

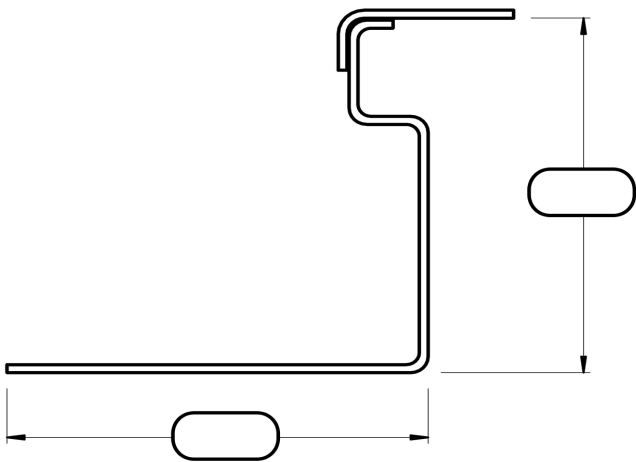

## LANDING RISER

QTY	Gauge	Length	Mark

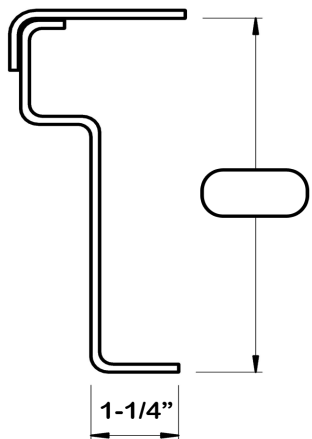

## STARTER RISER

QTY	Gauge	Length	Mark

ORDER FORMS MANUAL



Stair Components & Systems

1 (800) 285-3056

Customer	Type	<b>1C</b>
Order #	Scale	
Job Name	Date	

email: fab@eberliron.com

stairpans.com



# STAIRPAN TYPE 1D

## COMBINATION TREAD & RISER

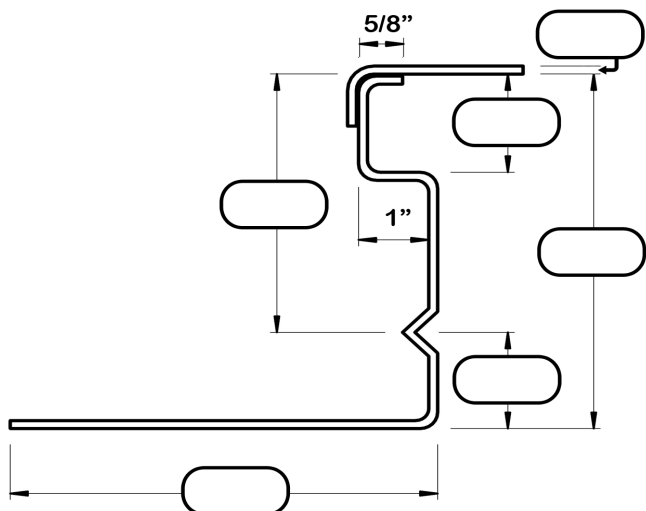

QTY	Gauge	Length	Mark

## LANDING RISER

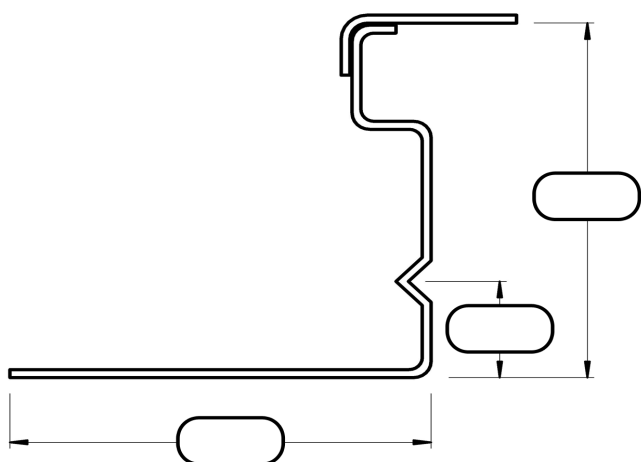

QTY	Gauge	Length	Mark

## STARTER RISER

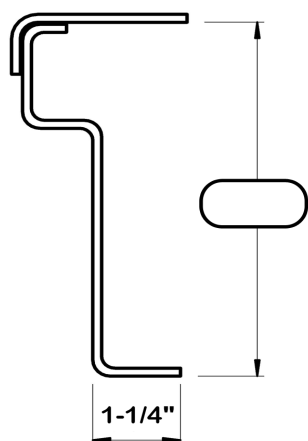

QTY	Gauge	Length	Mark

ORDER FORMS MANUAL



Stair Components & Systems

1 (800) 285-3056

Customer	Type	<b>1D</b>
Order #	Scale	
Job Name	Date	

email: fab@eberliron.com

stairpans.com

# STAIRPAN TYPE 2A

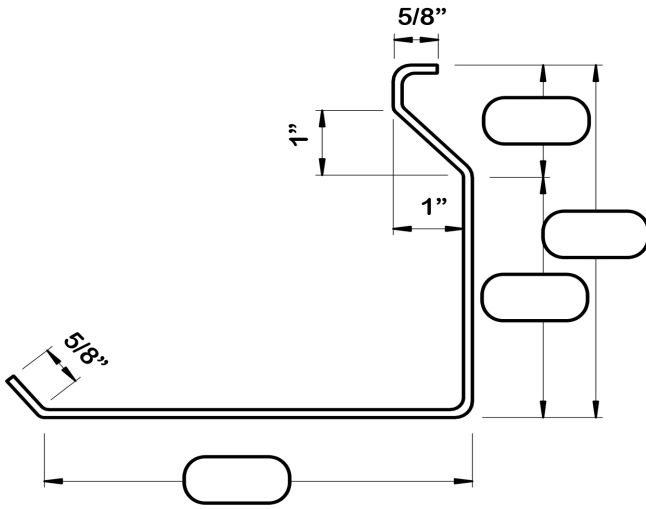

## COMBINATION TREAD & RISER

QTY	Gauge	Length	Mark

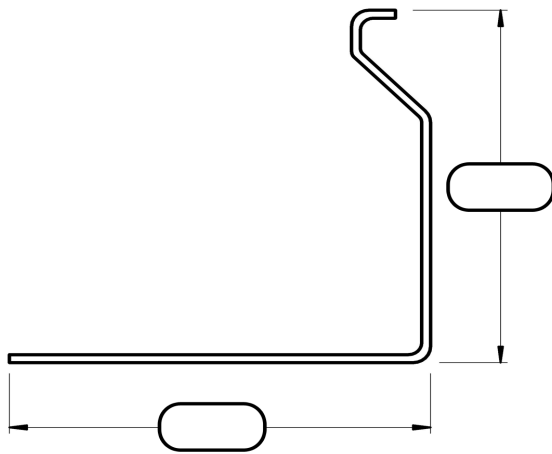

## LANDING RISER

QTY	Gauge	Length	Mark

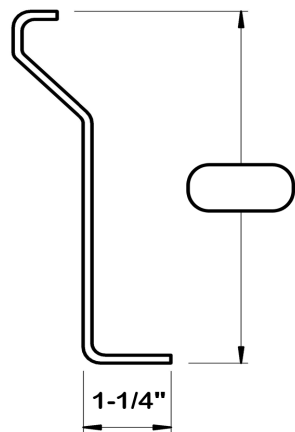

## STARTER RISER

QTY	Gauge	Length	Mark



Stair Components & Systems

1 (800) 285-3056

Customer	Type	<b>2A</b>
Order #	Scale	
Job Name	Date	

email: fab@eberliron.com

stairpans.com

# STAIRPAN TYPE 2B

## COMBINATION TREAD & RISER

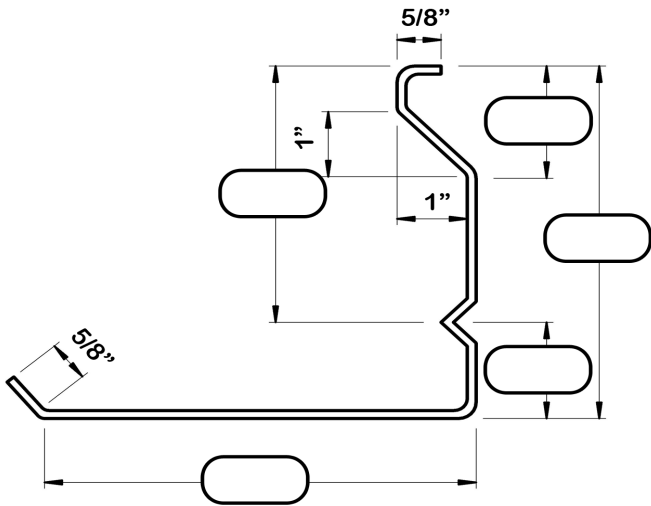

QTY	Gauge	Length	Mark

## LANDING RISER

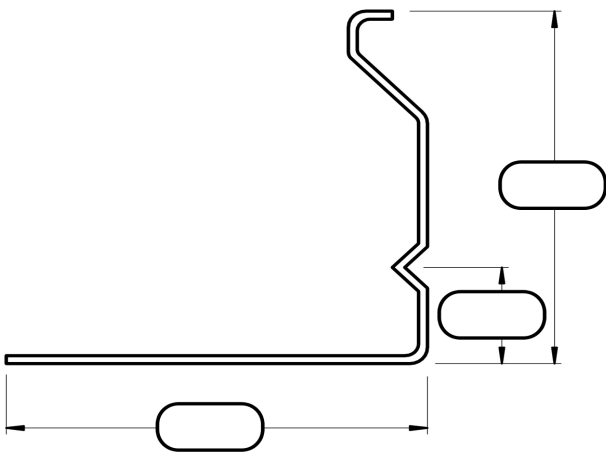

QTY	Gauge	Length	Mark

## STARTER RISER

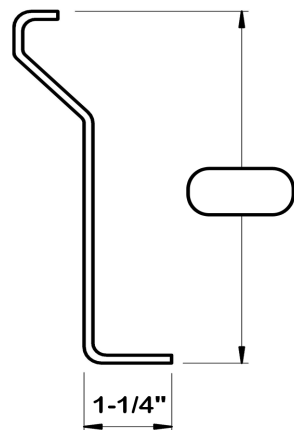

QTY	Gauge	Length	Mark

ORDER FORMS MANUAL



Stair Components & Systems

1 (800) 285-3056

Customer	Type	<b>2B</b>
Order #	Scale	
Job Name	Date	

email: fab@eberliron.com

stairpans.com

# STAIRPAN TYPE 2C

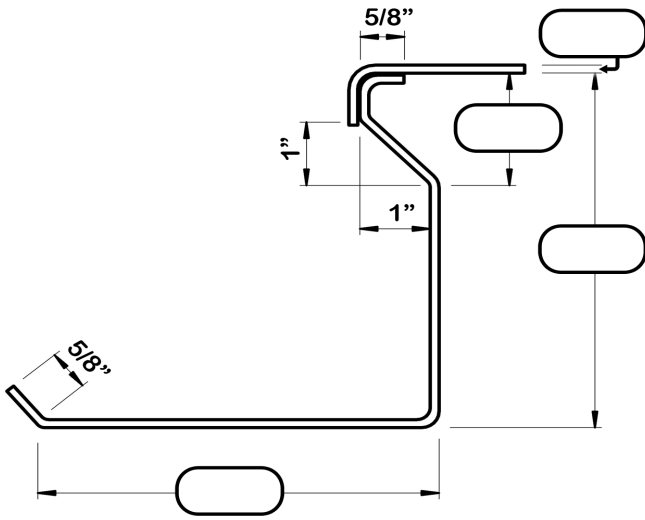

## COMBINATION TREAD & RISER

QTY	Gauge	Length	Mark

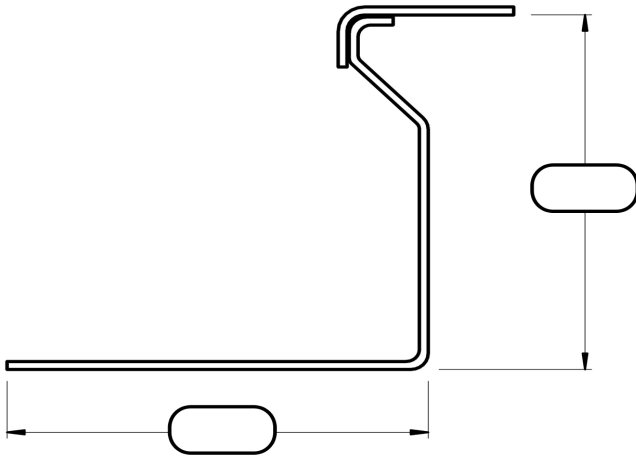

## LANDING RISER

QTY	Gauge	Length	Mark

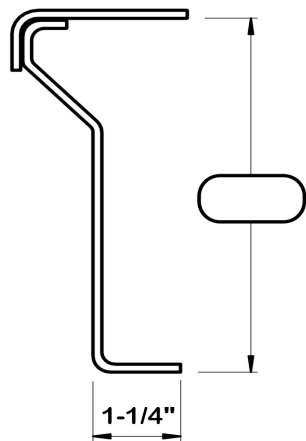

## STARTER RISER

QTY	Gauge	Length	Mark



Stair Components & Systems

1 (800) 285-3056

Customer	Type	<b>2C</b>
Order #	Scale	
Job Name	Date	

email: fab@eberliron.com

stairpans.com

# STAIRPAN TYPE 2D

## COMBINATION TREAD & RISER

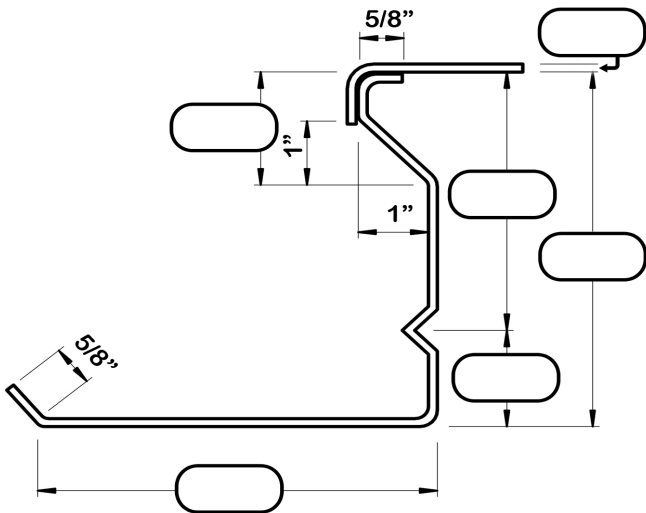

QTY	Gauge	Length	Mark

## LANDING RISER

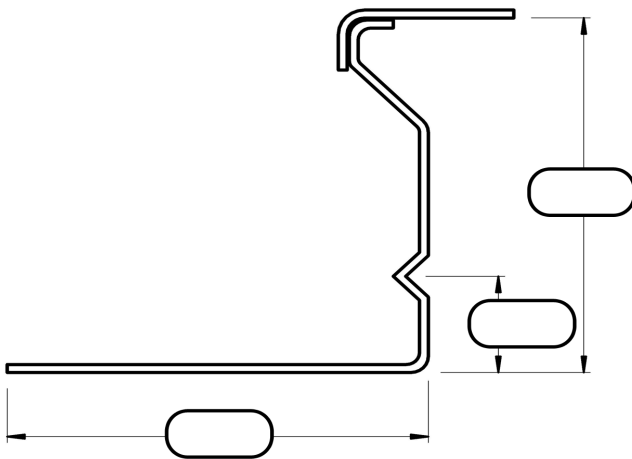

QTY	Gauge	Length	Mark

## STARTER RISER

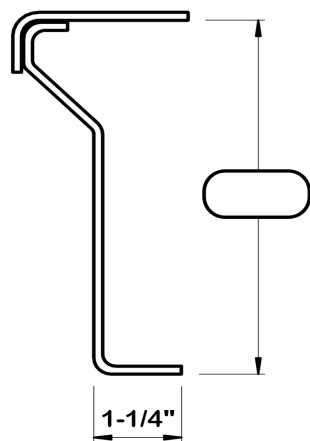

QTY	Gauge	Length	Mark



Stair Components & Systems

1 (800) 285-3056

Customer	Type	<b>2D</b>
Order #	Scale	
Job Name	Date	

email: fab@eberliron.com

stairpans.com

# STAIRPAN TYPE 3A

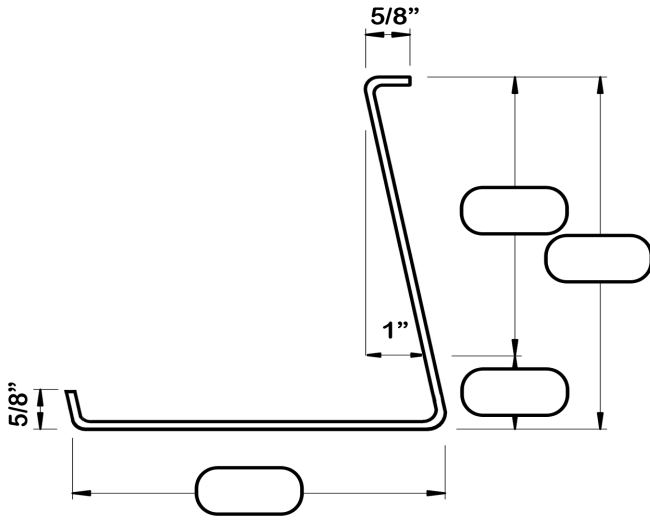

## COMBINATION TREAD & RISER

QTY	Gauge	Length	Mark

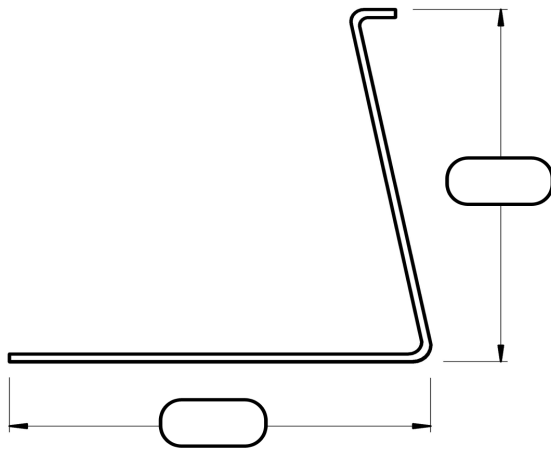

## LANDING RISER

QTY	Gauge	Length	Mark

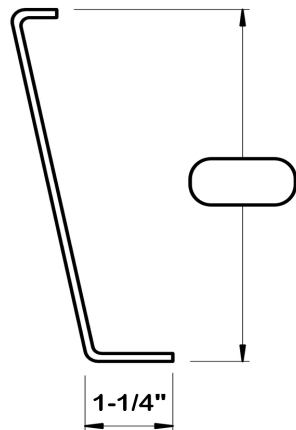

## STARTER RISER

QTY	Gauge	Length	Mark



Stair Components & Systems

1 (800) 285-3056

Customer	Type	<b>3A</b>
Order #	Scale	
Job Name	Date	

email: [fab@eberliron.com](mailto:fab@eberliron.com)

[stairpans.com](http://stairpans.com)

# STAIRPAN TYPE 3B

## COMBINATION TREAD & RISER

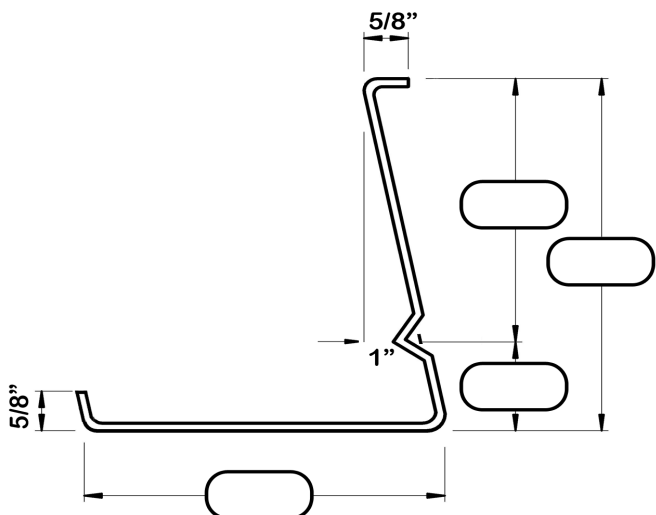

QTY	Gauge	Length	Mark

## LANDING RISER

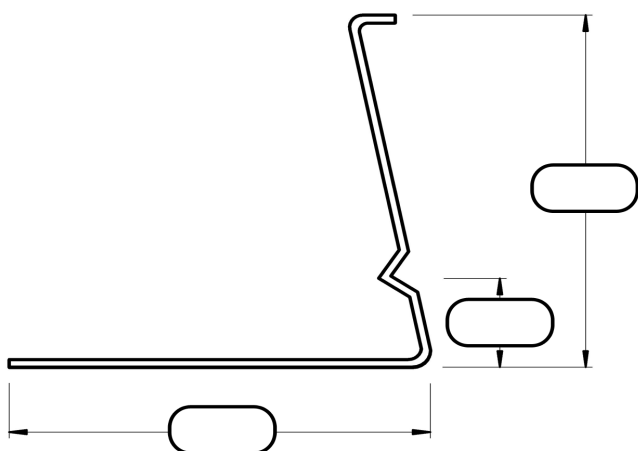

QTY	Gauge	Length	Mark

## STARTER RISER

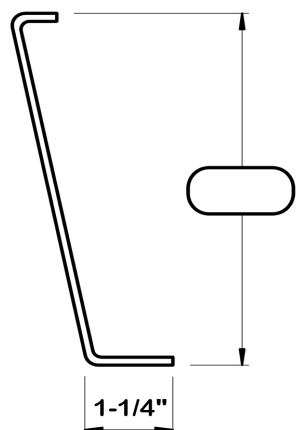

QTY	Gauge	Length	Mark

ORDER FORMS MANUAL



Stair Components & Systems

1 (800) 285-3056

Customer	Type	<b>3B</b>
Order #	Scale	
Job Name	Date	

email: fab@eberliron.com

stairpans.com

# STAIRPAN TYPE 3C

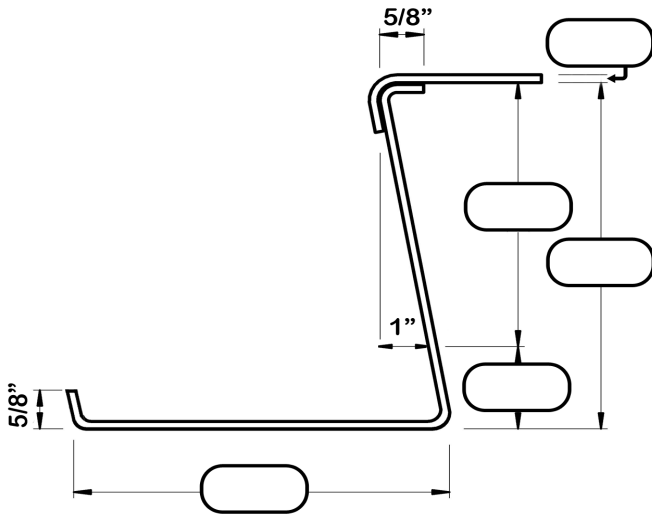

## COMBINATION TREAD & RISER

QTY	Gauge	Length	Mark

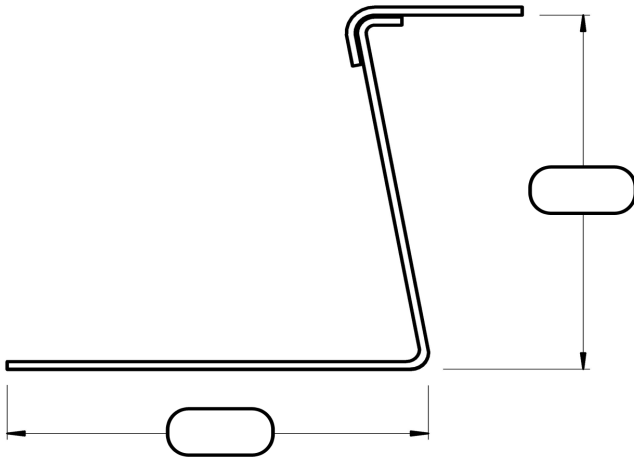

## LANDING RISER

QTY	Gauge	Length	Mark

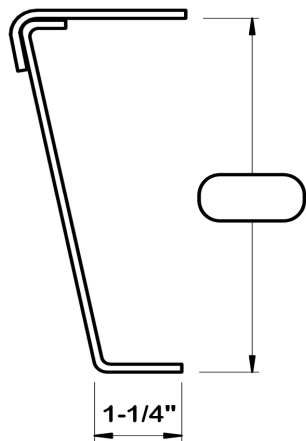

## STARTER RISER

QTY	Gauge	Length	Mark



Stair Components & Systems

1 (800) 285-3056

Customer	Type	<b>3C</b>
Order #	Scale	
Job Name	Date	

email: fab@eberliron.com

stairpans.com



# STAIRPAN TYPE 3D

## COMBINATION TREAD & RISER

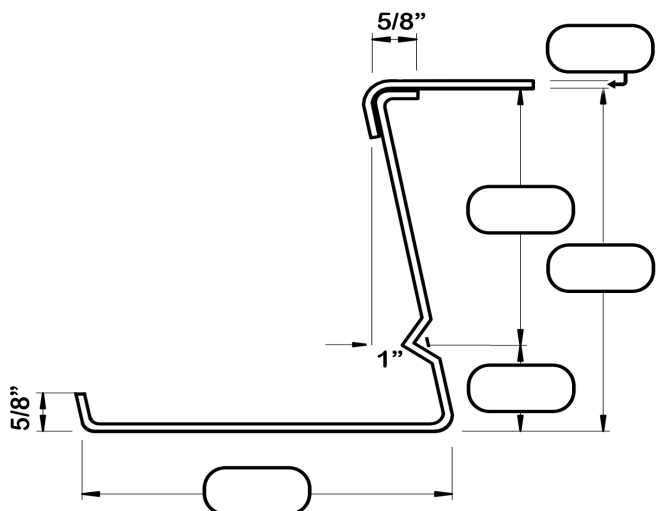

QTY	Gauge	Length	Mark

## LANDING RISER

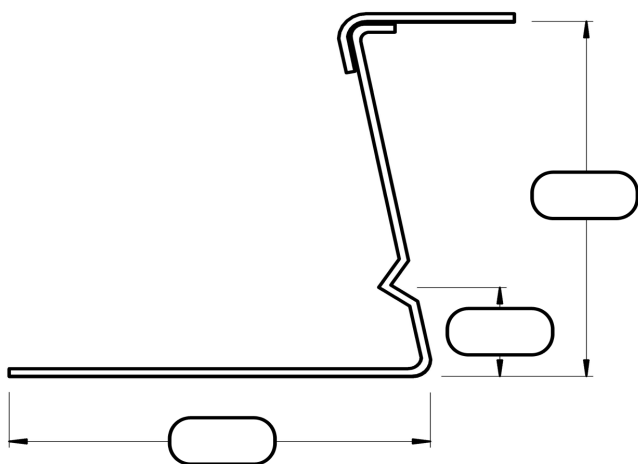

QTY	Gauge	Length	Mark

## STARTER RISER

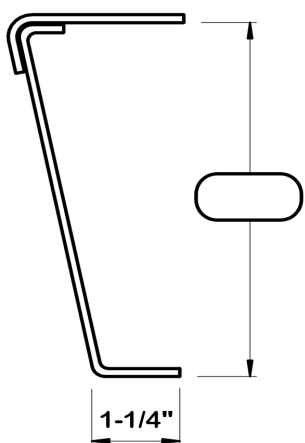

QTY	Gauge	Length	Mark

ORDER FORMS MANUAL



Stair Components & Systems

1 (800) 285-3056

Customer	Type	<b>3D</b>
Order #	Scale	
Job Name	Date	

email: fab@eberliron.com

stairpans.com

# STAIRPAN TYPE 4A

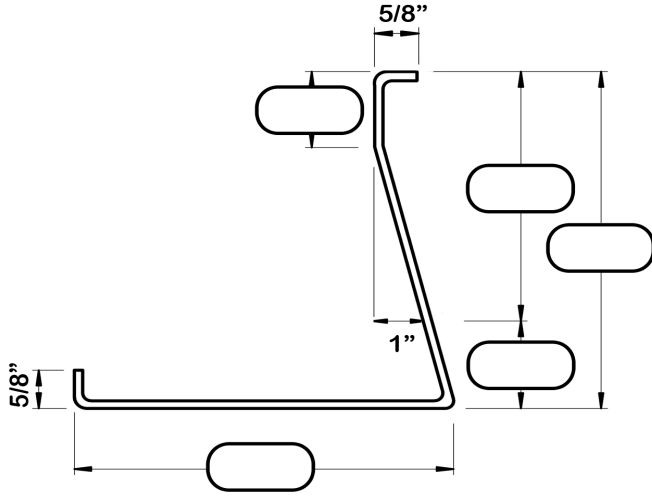

Nominal Tread (not including 1" nosing)

## COMBINATION TREAD & RISER

QTY	Gauge	Length	Mark

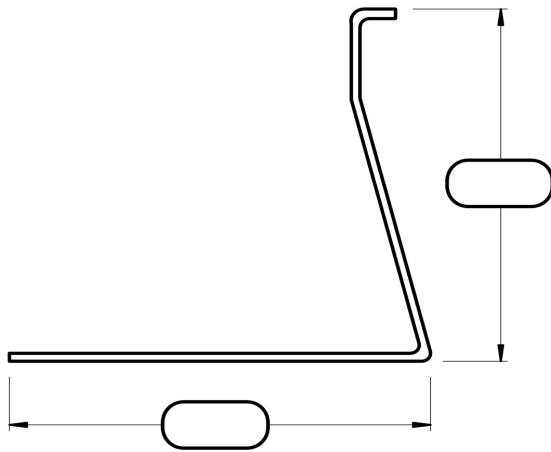

## LANDING RISER

QTY	Gauge	Length	Mark

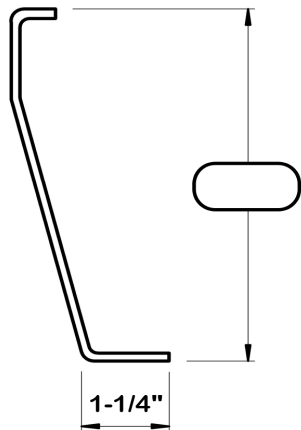

## STARTER RISER

QTY	Gauge	Length	Mark



Stair Components & Systems

1 (800) 285-3056

Customer	Type	<b>4A</b>
Order #	Scale	
Job Name	Date	

email: [fab@eberliron.com](mailto:fab@eberliron.com)

[stairpans.com](http://stairpans.com)

# STAIRPAN TYPE 4B

## COMBINATION TREAD & RISER

QTY	Gauge	Length	Mark

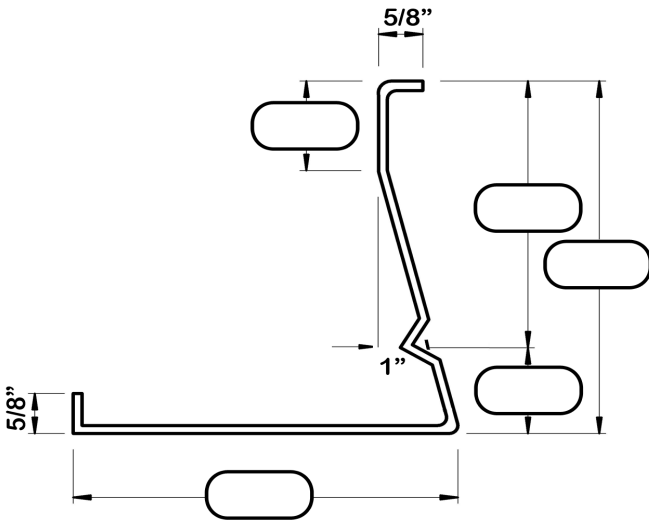

Nominal Tread (not including 1" nosing)

## LANDING RISER

QTY	Gauge	Length	Mark

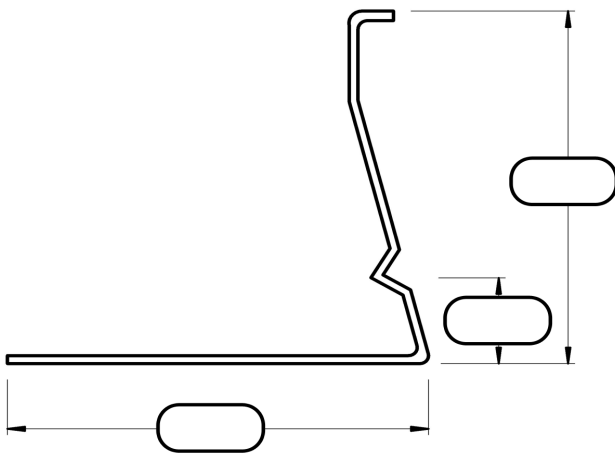

## STARTER RISER

QTY	Gauge	Length	Mark

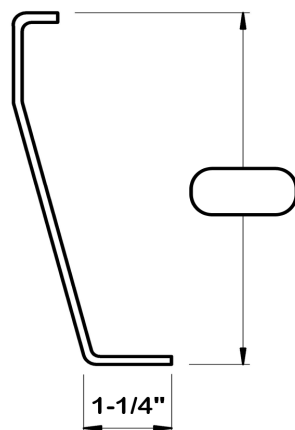

Stair Components & Systems

1 (800) 285-3056

Customer	Type	<b>4B</b>
Order #	Scale	
Job Name	Date	

email: fab@eberliron.com

stairpans.com

# STAIRPAN TYPE 4C

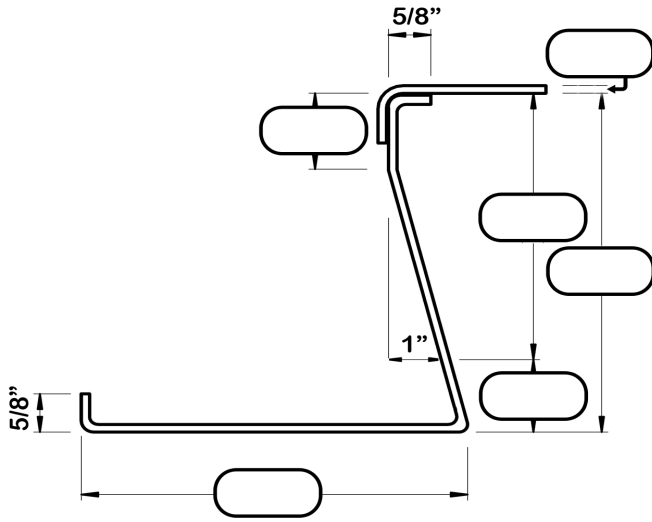

Nominal Tread (not including 1" nosing)

## COMBINATION TREAD & RISER

QTY	Gauge	Length	Mark

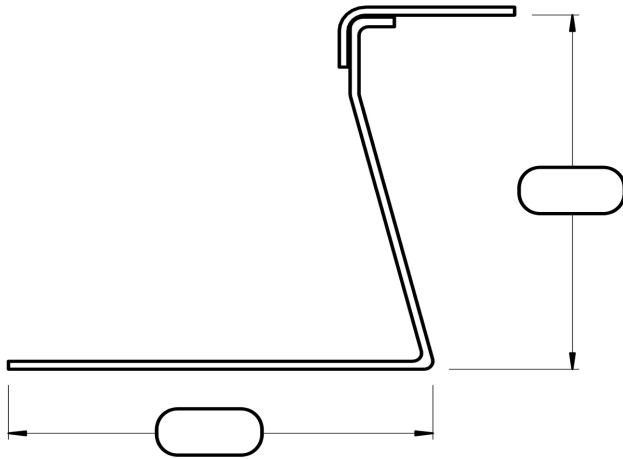

## LANDING RISER

QTY	Gauge	Length	Mark

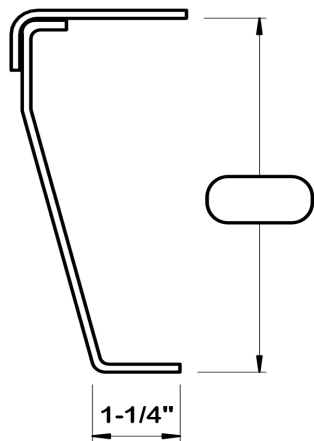

## STARTER RISER

QTY	Gauge	Length	Mark



Stair Components & Systems

1 (800) 285-3056

Customer	Type	<b>4C</b>
Order #	Scale	
Job Name	Date	

email: [fab@eberliron.com](mailto:fab@eberliron.com)

[stairpans.com](http://stairpans.com)

# STAIRPAN TYPE 4D

## COMBINATION TREAD & RISER

QTY	Gauge	Length	Mark

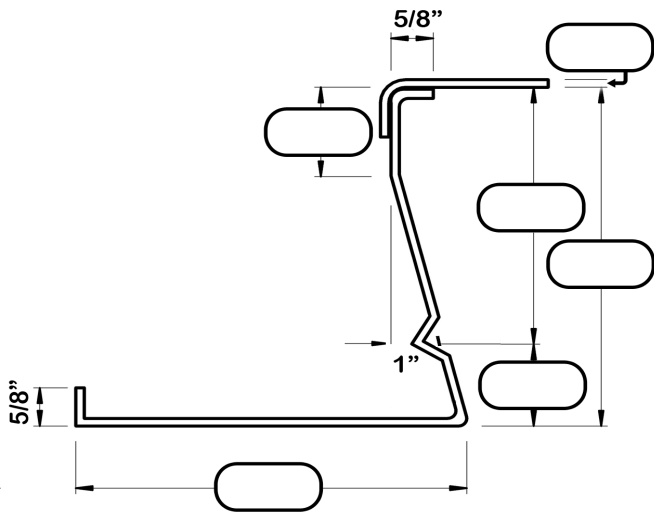

Nominal Tread (not including 1" nosing)

## LANDING RISER

QTY	Gauge	Length	Mark

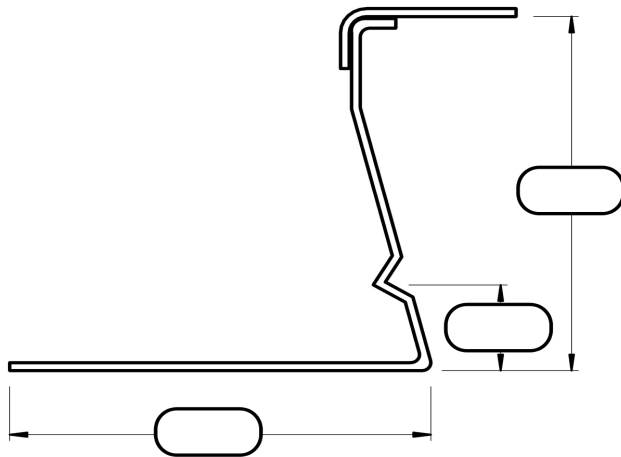

## STARTER RISER

QTY	Gauge	Length	Mark

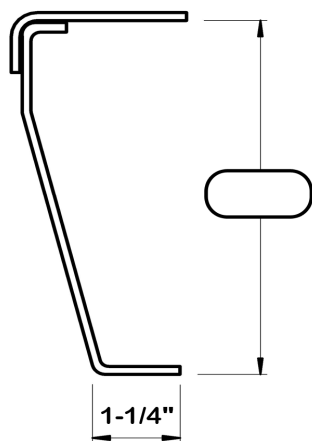

Stair Components & Systems

1 (800) 285-3056

Customer	Type	<b>4D</b>
Order #	Scale	
Job Name	Date	

email: fab@eberliron.com

stairpans.com

# LANDING PANS

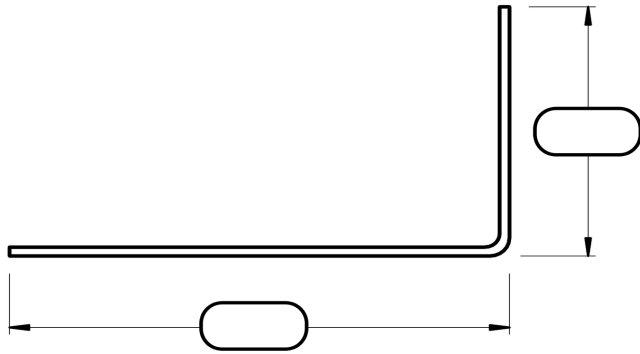

QTY	Thickness	Length	Mark

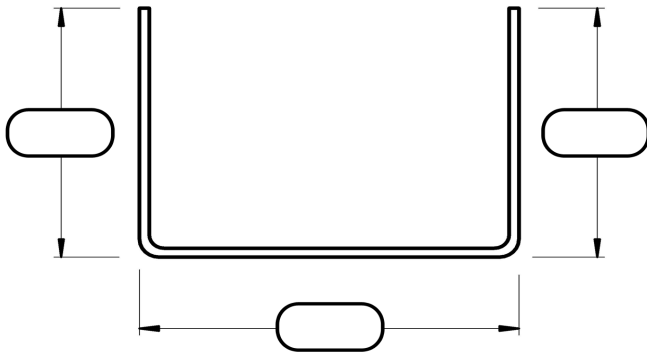

QTY	Thickness	Length	Mark

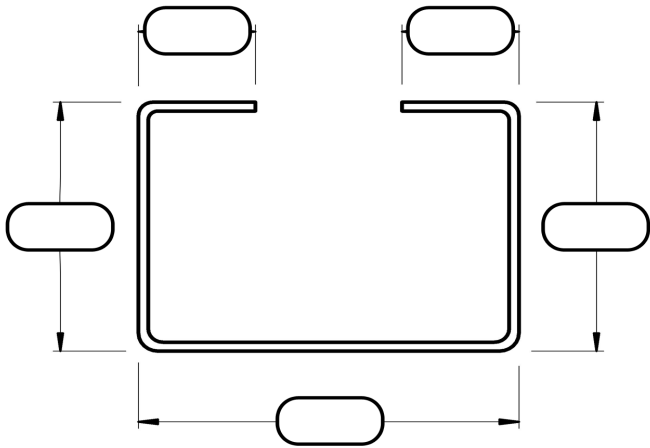

QTY	Thickness	Length	Mark



Stair Components & Systems

1 (800) 285-3056

Customer	Type	<b>LP</b>
Order #	Scale	
Job Name	Date	

email: [fab@eberliron.com](mailto:fab@eberliron.com)

[stairpans.com](http://stairpans.com)

# STAIR TREAD TYPE 20

## COMBINATION TREAD & RISER

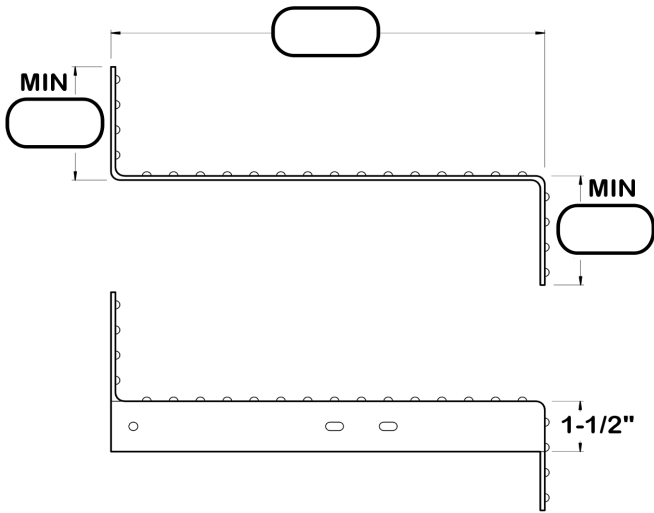

QTY	Floor Plate Thickness	Length	Mark

- Without Carrier Plate
- With Carrier Plate

## STARTER TREAD

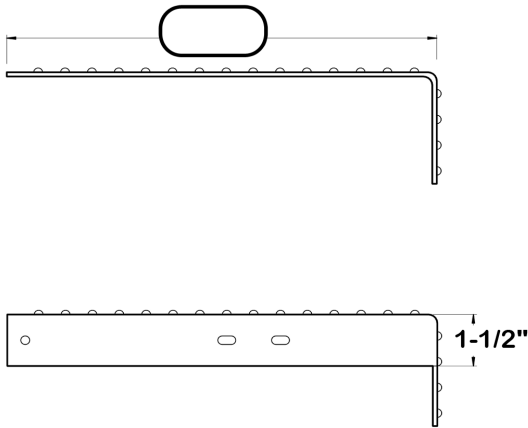

QTY	Floor Plate Thickness	Length	Mark

- Without Carrier Plate
- With Carrier Plate

\* Also available in aluminum tread plate

Thickness of Floor Plate	Min Outside Dimension of Lip
1/8" .....	1"
3/16" .....	1-1/2"
1/4" .....	1-1/2"

Customer	Type	<b>20</b>
Order #	Scale	
Job Name	Date	

# STAIR TREAD TYPE 25

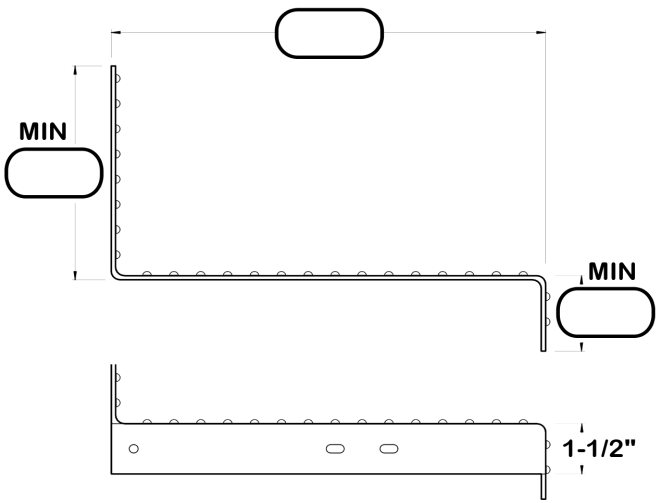

## COMBINATION TREAD & RISER

QTY	Floor Plate Thickness	Length	Mark

- Without Carrier Plate
- With Carrier Plate

## STARTER TREAD

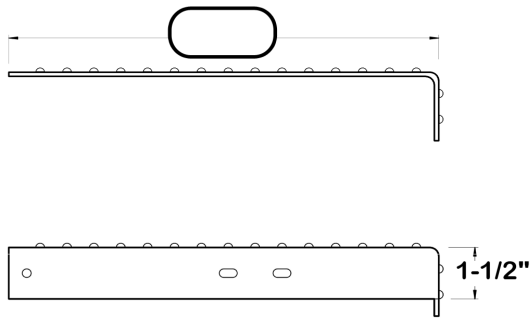

QTY	Floor Plate Thickness	Length	Mark

- Without Carrier Plate
- With Carrier Plate

\* Also available in aluminum tread plate

Thickness of Floor Plate	Min Outside Dimension of Lip
1/8" .....	1"
3/16" .....	1-1/2"
1/4" .....	1-1/2"



Stair Components & Systems

1 (800) 285-3056

Customer	Type	<b>25</b>
Order #	Scale	
Job Name	Date	

email: fab@eberliron.com

stairpans.com



# STAIR TREAD TYPE 26

## COMBINATION TREAD & RISER

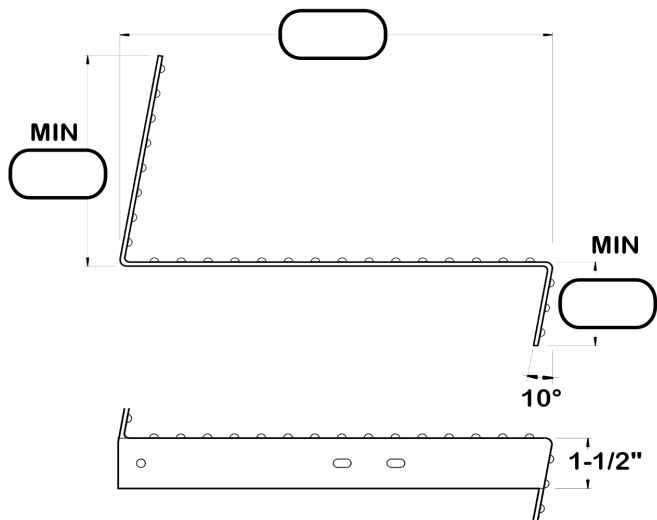

QTY	Floor Plate Thickness	Length	Mark

- Without Carrier Plate
- With Carrier Plate

## STARTER TREAD

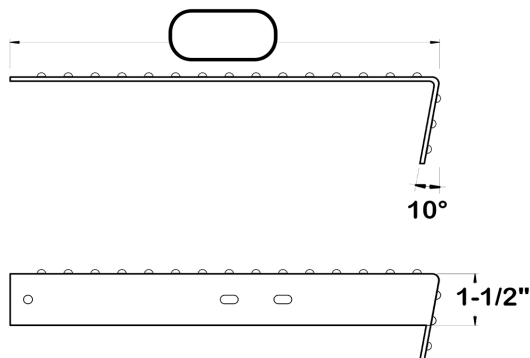

QTY	Floor Plate Thickness	Length	Mark

- Without Carrier Plate
- With Carrier Plate

\* Also available in aluminum tread plate

Thickness of Floor Plate	Min Outside Dimension of Lip
1/8" .....	1"
3/16" .....	1-1/2"
1/4" .....	1-1/2"

Customer	Type	<b>26</b>
Order #	Scale	
Job Name	Date	

# SPIRAL STAIR TREAD

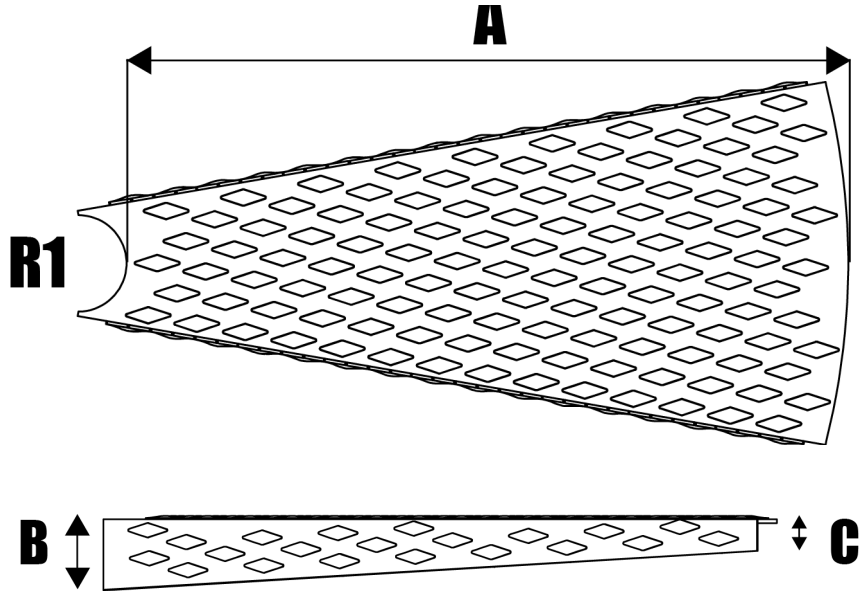
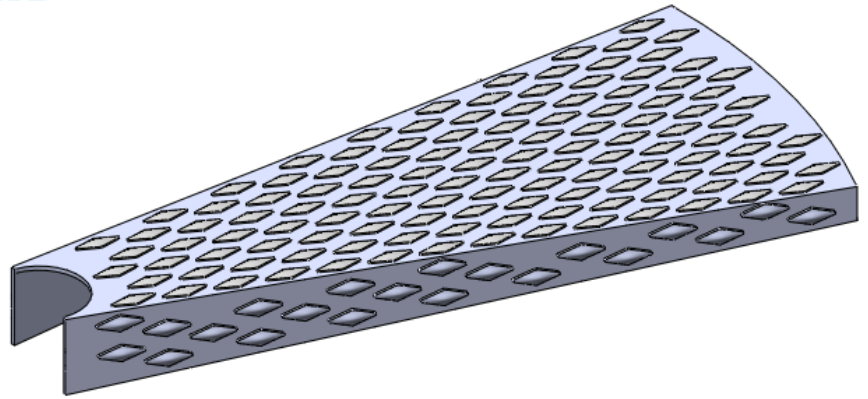
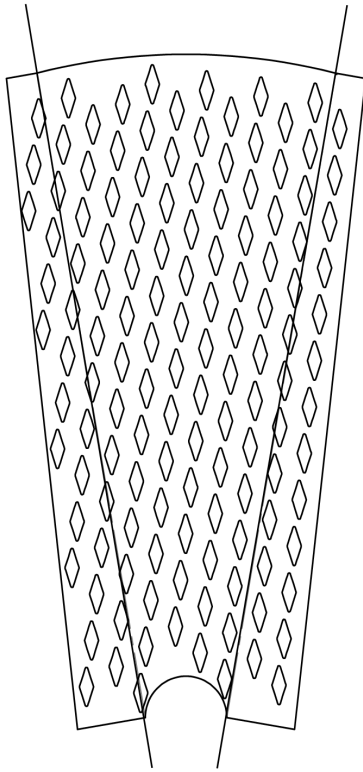

## CUSTOM SPIRAL STAIR TREAD

QTY	A	B	C	R1	R2

Material Thickness: \_\_\_\_\_



Stair Components & Systems

1 (800) 285-3056

Customer	Type	<b>SP</b>
Order #	Scale	
Job Name	Date	

email: [fab@eberliron.com](mailto:fab@eberliron.com)

[stairpans.com](http://stairpans.com)

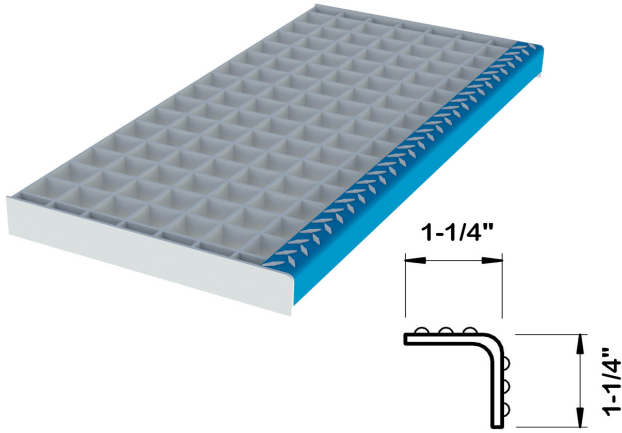

Cut to Length or in Random Lengths

QTY	Floor Plate Thickness	Length	Mark

\* Nosings are available in 1/8" and 3/16" Floor Plate and Aluminum Tread Plate

## CARRIER ANGLES

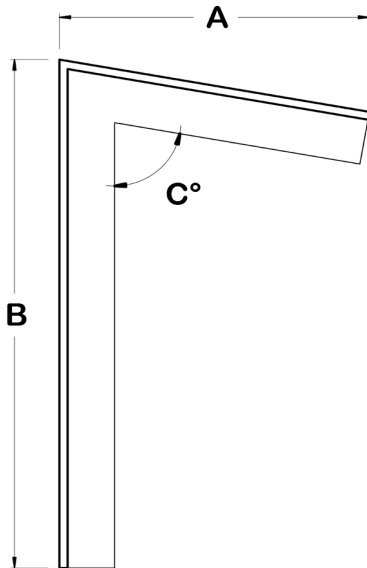

QTY	A	B	C

\* Please specify if you use a different riser support



Stair Components & Systems

1 (800) 285-3056

Customer	Type	<b>N/CA</b>
Order #	Scale	
Job Name	Date	

email: fab@eberliron.com

stairpans.com

# CAPABILITIES

We offer **metal shearing services** on plates between 20 gauge and 1/2" thicknesses, up to 12 feet in length. We shear flat bar in the following sizes: 1/2" thick by 20" wide, 3/4" thick by 18" wide, and 1" thick by 12" wide.

We also offer **metal forming services**. Our four Press Brakes can handle material as thin as 20 gauge and up to 3/8" thick, by 12 feet in length. We can form 1/2" thick material by 6 feet in length.

Other services we offer include: Coping/Notching, Plasma Cutting, Laser Cutting, Welding, Powder Coating, and Painting.

We use CNC equipment, along with a highly skilled workforce, to ensure the tightest tolerance levels, the most accuracy, and the highest efficiency on all of our metal fabrication jobs, so we can save you time and money.

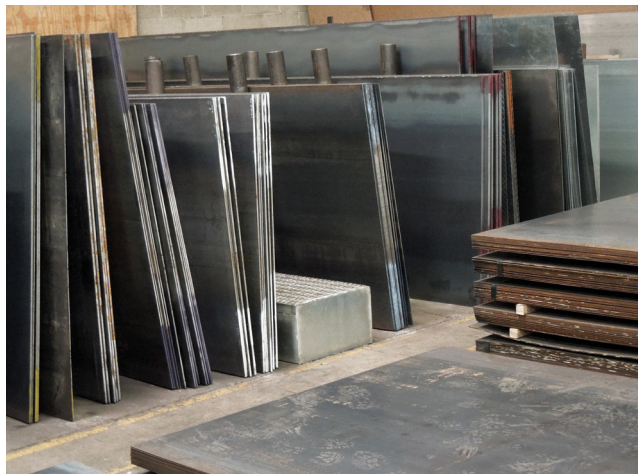

# MATERIALS

Our 40,000 square foot facility is stocked with a large array of materials, so we can fabricate your custom job at a moment's notice.

Because we offer so many different fabrication services in house, we are able to tightly control the manufacturing process.

This allows us to provide you with a **superior standard of quality and quick turnaround time on our products.**

Eberl Iron Works, Inc.  
128 Sycamore Street  
Buffalo, NY 14204  
1 (800) 285-3056  
Local (716) 854-7633  
Fax: (716) 854-1184  
Email: fab@eberliron.com



**Stair Components & Systems**  
A Division of Eberl Iron Works, Inc.

[stairpans.com](http://stairpans.com)



## Shipping & Delivery

We keep a large selection of products in inventory so we can cut our lead times down and fulfill orders in as few days as possible. Our extremely high shipping volumes are a major contributing factor to our ability to provide highly competitive product pricing and delivery throughout North America. All of our quotes include delivery to your chosen destination.

Your stairpans are skidded, bound, and marked for delivery. Bundles are neatly nested. Each order is marked per your job prints for EASY location and assembly, because we recognize that your time is valuable. We take pride in delivering accurate, clean, pre-sorted stairpans, stair treads and stair components, on time.